

Apartment Design Guidelines for Victoria



Cover photo: Hawke + King apartments

The apartment development is planned around a central outdoor communal open space with canopy trees. The building's exteriors are of robust materials, and landscaping in planters softens the street edge.

Architect: Six Degrees Architects. Landscaping: TNLA Landscape Architects. Photo: Greg Elms.

Acknowledgment

We acknowledge and respect Victorian Traditional Owners as the original custodians of Victoria's land and waters, their unique ability to care for Country and deep spiritual connection to it. We honour Elders past and present whose knowledge and wisdom has ensured the continuation of culture and traditional practices.

We are committed to genuinely partner and meaningfully engage with Victoria's Traditional Owners and Aboriginal communities to support the protection of Country, the maintenance of spiritual and cultural practices and their broader aspirations in the 21st century and beyond.

© The State of Victoria Department of Environment, Land, Water and Planning 2021.



This work is licensed under a Creative Commons Attribution 4.0 International licence. You are free to re-use the work under that licence, on the condition that you credit the State of Victoria as author. The licence does not apply to any images, photographs or branding, including the Victorian Coat of Arms, the Victorian Government logo and the Department of Environment, Land, Water and Planning (DELWP) logo. To view a copy of this licence, visit <http://creativecommons.org/licenses/by/4.0/>

ISBN 978-1-76105-410-5 (print)

ISBN 978-1-76105-408-2 (pdf)

Disclaimer

This publication may be of assistance to you but the State of Victoria and its employees do not guarantee that the publication is without flaw of any kind or is wholly appropriate for your particular purposes and therefore disclaims all liability for any error, loss or other consequence which may arise from you relying on any information in this publication.

Accessibility

If you would like to receive this publication in an alternative format, please telephone the DELWP Customer Service Centre on 136 186, or email customer.service@delwp.vic.gov.au, or via the National Relay Service on 133 677, www.relayservice.com.au. This document is also available on the internet at www.delwp.vic.gov.au

Contents

Introduction	4
Structure of the guidelines	5
Application of the apartment standards	6
Urban context and design response	7
Section 1 - SITING AND BUILDING ARRANGEMENT	11
Guidance to building setback	11
Guidance to communal open space	20
Guidance to solar access to communal outdoor open space	30
Guidance to landscaping	32
Guidance to external walls and materials	48
Guidance to wind impacts	57
Guidance to integration with the street	68
Guidance to access	76
Guidance to site services	82
Guidance to building entry and circulation	91
Section 2 - BUILDING PERFORMANCE	95
Guidance to noise impacts	95
Guidance to energy efficiency	102
Guidance to waste and recycling	106
Guidance to integrated water and stormwater management	111
Section 3 - DWELLING AMENITY	114
Guidance to functional layout	114
Guidance to room depth	117
Guidance to windows	120
Guidance to storage	123
Guidance to natural ventilation	126
Guidance to private open space	129
Guidance to accessibility	139
Guidance to construction impacts	145
Glossary	146

Introduction

Victorians want high-quality, liveable, attractive apartments. They want apartments that are ‘greener’ buildings — that have better environmental performance — and that have more robust external materials, are safe, contribute to residents’ health and wellbeing and maintain and improve neighbourhood amenity. They want diverse, affordable housing options now and a legacy of quality housing stock for future generations.

The Better Apartment Design Standards

In 2017, the [Better Apartment Design Standards](#) — called ‘the apartment standards’ in this document — were implemented in the Victoria Planning Provisions and all planning schemes. Before then, there had been little planning guidance for apartments, which had led to a proliferation of buildings with windowless, tiny bedrooms and unhealthy spaces. The Victorian Government’s aim was to ensure that apartments deliver diverse, well-designed housing options to meet the long-term needs of Victoria’s growing community.

The apartment standards introduced in 2017 were intended to improve the internal design of apartments and make them more liveable and sustainable. In 2021, the government extended these standards to improve the external design of apartment developments: with canopy trees, high-quality facades and pleasant, engaging street fronts protected from the wind.

Apartment Design Guidelines for Victoria 2021

The 2017 *Apartment Design Guidelines for Victoria* supported the implementation of the apartment standards by providing guidance for applicants, architects, building designers and planners to apply the standards through the planning permit application process.

This 2021 update to the design guidelines provides guidance about the new external wall and materials and the new wind impacts standards. It also provides guidance about the updates to the communal open space, landscaping, integration with the street, access, site services and the private open space standards. The aim is to achieve quality, liveable and attractive apartment buildings that increase green canopy cover in urban areas and contribute positively to the neighbourhood.

In introducing the apartment standards with these supporting guidelines, the government aims to support the work of design professionals — led by experienced architects or building designers — who can analyse and integrate the multiple requirements into a successful design that contributes positively to the urban context and the neighbourhood character. Alternative design solutions may be proposed, and the responsible authority will assess how an alternative solution meets the objectives. This is an important aspect of innovation.

The *Apartment Design Guidelines for Victoria 2021* are for use by applicants, architects, building designers, landscapers and planners for designing and assessing apartment developments. The guidance will support conversations between architects and planners and building designers and planners to promote compliance with the standards, without stifling creativity. It does this by providing a range of practical design ideas that comply with the standards, supported by photos and illustrations. The guidance should also lead to greater consistency by planners and others who assess planning permit applications for apartment developments.

The apartment standards and guidelines — which are further complemented by the [Urban Design Guidelines for Victoria](#), with advice about creating functional and enjoyable public places — will support state and local governments and the urban development sector to deliver high-quality, liveable, attractive apartment developments.

Structure of the guidelines

The *Apartment Design Guidelines for Victoria 2021* are presented in three sections, each of which addresses several apartment standards.

Each apartment standard has a chapter, which includes:

- the types of apartment developments to which it applies and the relevant clause in the [Victoria Planning Provisions](#) requiring it to be applied
- the objectives of applying the standard, the standard and the decision guidelines, which are matters the responsible authority should consider before deciding on an application: all these are reproduced from the relevant clause
- design guidance, which is in the form of suggestions and ideas, often with illustrations and good practice examples to stimulate creativity and innovation, about how the objectives can be achieved.

The three sections and their apartment standards are interrelated and require an integrated approach to achieve the objectives.

Section 1 - Siting and Building Arrangement

This section reinforces the importance of considering the urban context and the design response to it as a starting point for the design: the apartment standards mainly relate to the design and configuration of a building at the site scale. This involves assessing the immediate context, adjacent buildings and public realm.

The guidelines relate to how the building envelope — its three-dimensional volume — is established through appropriate building types, orientation and setbacks.

Siting the building also establishes where communal open space is located, how the landscaping is incorporated into the building, how the external walls and materials are treated, what kind of wind impacts may result, how the building integrates with the street and how entries and shared circulation are arranged.

This section includes the following apartment standards:

1. Building setback
2. Communal open space*
3. Solar access to communal outdoor open space
4. Landscaping*
5. External walls and materials*
6. Wind impacts*
7. Integration with the street*
8. Access*
9. Site services*
10. Building entry and circulation.

Section 2 - Building Performance

This section addresses performance issues that need to be considered when designing the building (such as noise impacts, energy performance and management of water and waste). These issues require consideration at both a site scale and at a more detailed building-systems level. These apartment standards relate closely to other environmental assessment tools and typically require specialist input to support the design response.

This section includes the following apartment standards:

11. Noise impacts
12. Energy efficiency
13. Waste and recycling
14. Integrated water and stormwater management.

Section 3 - Dwelling Amenity

This section addresses the detailed design of individual dwellings including amenity issues (such as access to daylight and ventilation through arrangements of windows and room depths) as well as functional and accessible layouts of internal and external space.

This section includes the following apartment standards:

15. Functional layout*
16. Room depth
17. Windows
18. Storage
19. Natural ventilation
20. Private open space*
21. Accessibility.

This section also includes guidance about managing construction impacts.

**The 2021 update to the standards amended existing guidance or added new guidance about the new or updated standards with an asterisk: the update did not change guidance about the standards without an asterisk.*

Application of the apartment standards

The apartment standards apply to all apartment developments in Victoria.

The apartment standards are in the *Victoria Planning Provisions* and all planning schemes in:

- Clause 55 (Two or more dwellings on a lot and Residential buildings) at [Clause 55.07 \(Apartment Developments\)](#)
- A particular provision at [Clause 58 \(Apartment Developments\)](#).

Apartment developments of:

- Four or fewer stories (excluding a basement) in a residential zone will be assessed against most of the apartment standards under Clause 55, which includes new Apartment Standards at Clause 55.07.
- Five or more storeys (excluding a basement) in a residential zone and all other zones will be assessed against Clause 58.

The 2017 [Planning Advisory Note 66: New planning provisions for apartment developments – Amendment VC136](#) details how the apartment standards are given effect in Clause 55.07 and Clause 58.

These guidelines relate to Clause 55.07 and Clause 58 provisions.

Operation of the apartment standards

The apartment provisions operate in the same way that Victoria Planning Provisions clauses 54 and 55 operate to assess residential development. The provisions have objectives, apartment standards and decision guidelines.

An objective describes the desired outcomes to be achieved in the completed development.

A standard sets out requirements to meet the objective. Normally, a standard should be met, but if the responsible authority is satisfied that an alternative design solution meets the objective, the alternative design solution may be considered.

Decision guidelines set out the matters the responsible authority should consider before deciding if an application meets the objectives. When an alternative design solution is proposed, the effect of the design solution on the achievement of other objectives should be considered.

Requirements

An apartment development:

- must meet of the objectives of Clause 55 or Clause 58.
- should meet the apartment standards of Clause 55 or Clause 58.

The apartment standards in Clause 55.07 cannot be varied in a schedule to a zone. Some existing standards in Clause 55 continue to be able to be varied in a schedule to a zone.

The Neighbourhood Character Overlay will continue to allow variations to most standards in Clause 55, except for the apartment standards in Clause 55.07 and existing key amenity standards (such as overshadowing and daylight to new and existing windows).

Apartment standards in Clause 58 cannot be varied in a schedule to the zone or an overlay, except for the D 14 building setback standard in [Clause 58.04 \(building setback standard\)](#).

Urban context and design response

Neighbourhood and site description and design response

For apartment developments of four or fewer storeys (excluding a basement) in a residential zone, [Clause 55.01 \(Neighbourhood and site description and design response\)](#) requires a neighbourhood and site description and design response to be prepared and submitted with a planning permit application.

A neighbourhood and site description must accurately describe the features or characteristics of the neighbourhood and site. It is a factual record of the physical features of the neighbourhood and site, so it should be impartial and describe their positive and negative features.

A design response must explain how the proposed design:

- Derives from and responds to the neighbourhood and site description.
- Meets the objectives of Clause 55.
- Responds to any neighbourhood character features for the area identified in a local planning policy or a Neighbourhood Character Overlay.

If the application is for an apartment development, the design response must explain how the proposed design selects materials and finishes for the external walls.

The design response must include correctly proportioned street elevations or photographs showing the development in the context of adjacent buildings. If in the opinion of the responsible authority this requirement is not relevant to the evaluation of an application, it may waive or reduce the requirement.

There is more information about preparing a neighbourhood and site description and design response in:

- [Planning Practice Note 16: Making an Application for a Dwellings in a Residential Zone](#)
- [Planning Practice Note 43: Understanding Neighbourhood Character](#).

Urban context report and design response

For apartment developments of five or more storeys (excluding a basement) in a residential zone and all apartment developments in other zones, [Clause 58.01 \(Urban Context Report and Design Response\)](#) requires an urban context report and design response to be prepared and submitted with an application.

An urban context report must accurately describe the features or characteristics of the urban context and the site. An urban context report is not a justification for a preconceived design: it is a factual record of the physical features of the urban context and site, so it should be impartial and describe their positive and negative features.

The design response must explain how the proposed design:

- Responds to any relevant planning provision that applies to the land.
- Meets the objectives of Clause 58.
- Responds to any relevant housing, urban design and landscape plan, strategy or policy set out in this scheme.
- Selects materials and finishes for the external walls.
- Derives from and responds to the urban context report.

The design response must include correctly proportioned street elevations or photographs showing the development in the context of adjacent buildings. If in the opinion of the responsible authority this requirement is not relevant to the evaluation of an application, it may waive or reduce the requirement.

Urban context

The starting point for a new apartment design is its urban context, which refers to the strategic setting of the development. It includes the natural, social and economic environment of the area, existing physical surroundings, features that make a particular place distinctive, neighbourhood character and the likely future character of the area. In some cases, urban context refers to valued aspects of the existing character. In other circumstances (such as urban renewal precincts), it may refer to an emerging or preferred future character.

Across Victoria, each location and site is different. Defining the context establishes the parameters for apartment development and how new buildings should respond to the area's character. The development proposal will derive its design response from its unique urban context. It will need to demonstrate that it takes into account the context and all the apartment standards, to deliver acceptable apartment amenity and support the liveability of surrounding neighbourhoods.

Design response

The neighbourhood and site description or urban context report assists in determining the most appropriate building type and site layout for a residential development. Different building types may be appropriate within different contexts depending on individual site characteristics. A context may have more than one building type, scale and character, or multiple interface conditions (such as public space and commercial uses). It may be appropriate for a development to respond by providing a diversity of building forms and dwelling types.

A design response derives from and responds to the neighbourhood and site description or urban context report and any applicable local planning provisions, as well as the objectives in the apartment standards.

Guidance on responding to contexts

Distinctive features and characteristics in different contexts should be considered when designing an apartment development. Below are four typical contexts: Central city (tower and podium), Activity centres, Neighbourhood centres and Residential neighbourhoods.

Central City (Tower and Podium)

This context is characterised by taller building forms, often as tower and podium, such as are found in central city areas. These areas are characterised by high commercial and residential intensity, high site coverage and a strong urban character. Considerations for residential apartment development in this context include managing complex relationships with adjacent buildings and spaces. This urban context may include heritage buildings and places, adjacent tall buildings and high-amenity public spaces.

In this context, planning schemes outline detailed controls for building setback and height. The design response in this context should generally increase setback with building height and may require consideration of wind effects, noise and the availability of public open space.

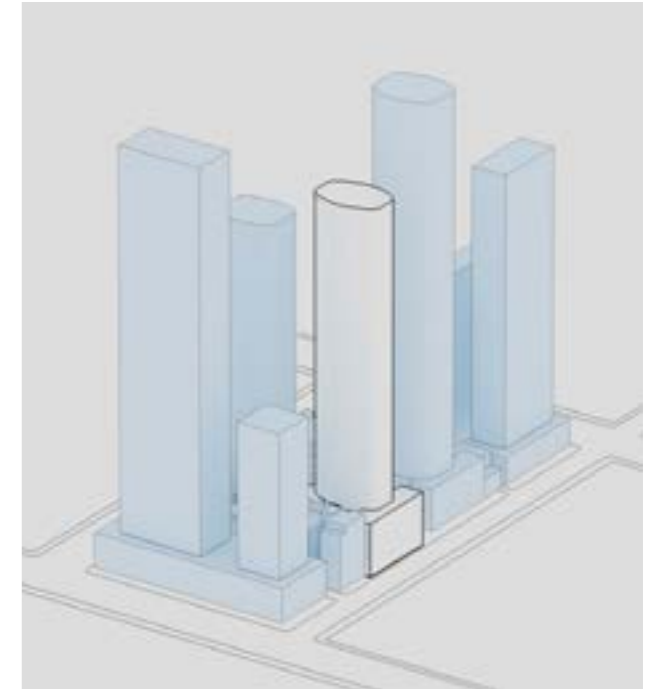

Activity Centres

This context is characterised by medium-rise built form, typically on larger or consolidated sites. These areas have medium-to-high levels of residential and commercial intensity and an active public realm. New apartment developments (which may include mixed uses) often have zero setbacks to the street frontage and may be adjacent to heritage and other sensitive interfaces. Planning controls may detail the preferred character and built form. The design response will typically require high site coverage at lower levels, with setbacks required at upper levels.

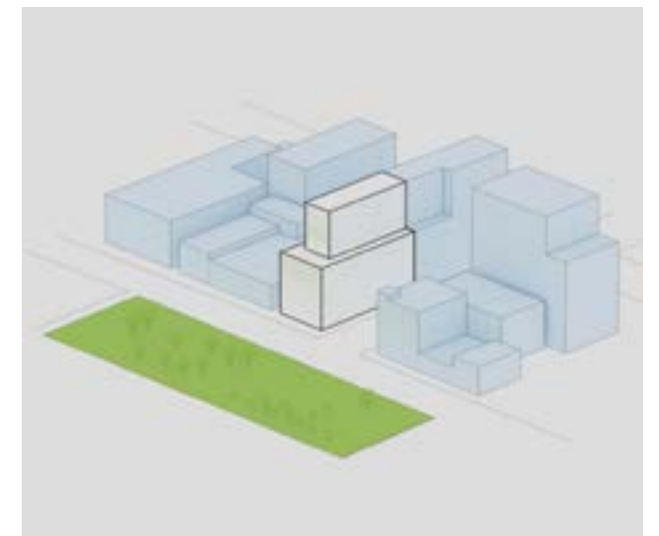

Neighbourhood Centres

This context is characterised by varied site configurations, typically in established shopping strips. Lower-rise buildings on smaller sites are generally built up to side boundaries and the street frontage. New apartment development may interface with sensitive, lower-density residential uses or heritage buildings. Development should address the pattern of building setbacks, the amenity of surrounding dwellings and the quality and type of landscape.

Specific planning controls may be in place to guide built form and character. The building form above street frontages may require further setbacks with front and rear orientation of apartments appropriate for narrow infill sites to achieve amenity objectives.



Residential Neighbourhoods

This context is characterised by lower-rise, residential buildings including detached houses and townhouses, as well as infill apartment development in appropriate residential zones.

New apartment development should be responsive to the low-rise residential character of the area.

Low-rise apartment buildings typically require setbacks to the street and other boundaries to achieve amenity objectives and respond to the preferred landscape character.



Section 1 - Siting and Building Arrangement

Guidance to building setback

Why this is important

Building setbacks at side, rear and internal to the site contribute to apartment amenity by providing access to daylight, sunlight, visual privacy, outlook and ventilation to buildings, and may provide space for landscaping. Setbacks will vary in response to a building's urban context and contribute to the character of the area. Setbacks ensure acceptable apartment amenity is derived from within the site and from the public realm.

Application

Clause 58.04-1 (Building setback) applies to apartment developments of five or more storeys (excluding a basement) in a residential zone and all apartment developments in other zones.

Building setback objectives (Clause 58.04-1)

To ensure the setback of a building from a boundary appropriately responds to the existing urban context or contributes to the preferred future development of the area.

To allow adequate daylight into new dwellings.

To limit views into habitable room windows and private open space of new and existing dwellings.

To provide a reasonable outlook from new dwellings.

To ensure the building setbacks provide appropriate internal amenity to meet the needs of residents.

Standard (D14)

The built form of the development must respect the existing or preferred urban context and respond to the features of the site.

Buildings should be set back from side and rear boundaries, and other buildings within the site to:

- Ensure adequate daylight into new habitable room windows.
- Avoid direct views into habitable room windows and private open space of new and existing dwellings. Developments should avoid relying on screening to reduce views.
- Provide an outlook from dwellings that creates a reasonable visual connection to the external environment.
- Ensure the dwellings are designed to meet the objectives of Clause 58.

Decision guidelines

Before deciding on an application, the responsible authority must consider:

- The purpose of the zone and/or overlay that applies to the land.
- Any relevant urban design objective, policy or statement set out in this scheme.
- The urban context report.
- The design response.
- The relationship between the proposed building setback and the building setbacks of existing adjacent buildings, including the interface with laneways.
- The extent to which the proposed dwellings are provided with reasonable daylight access through the layout of rooms and the number, size, location and orientation of windows.
- The impact of overlooking on the amenity of existing and proposed dwellings.
- The existing extent of overlooking into existing dwellings and private open space.
- Whether the development meets the objectives of Clause 58

Design guidance

Interpreting the standard

A setback dimension is measured from the site boundary to the external surface of the habitable room window or the open side of the balcony, whichever is the lesser.

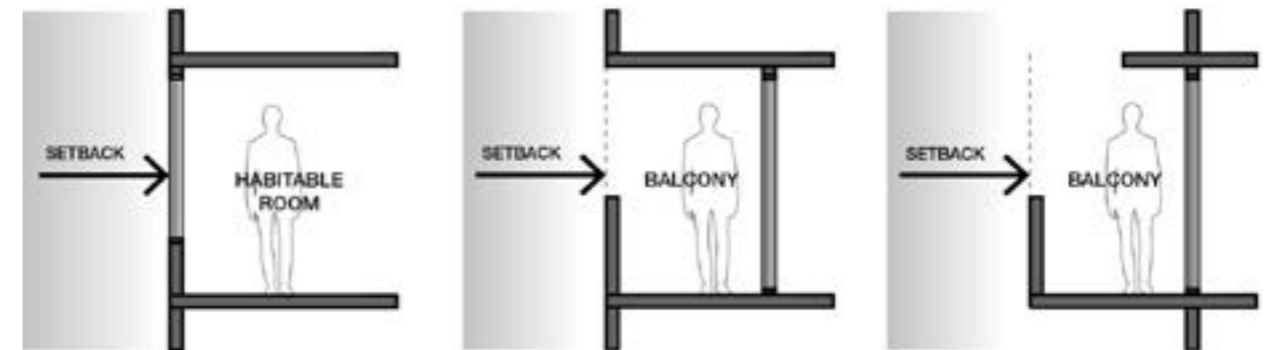

Measure setbacks to laneways from the centre of the laneway.

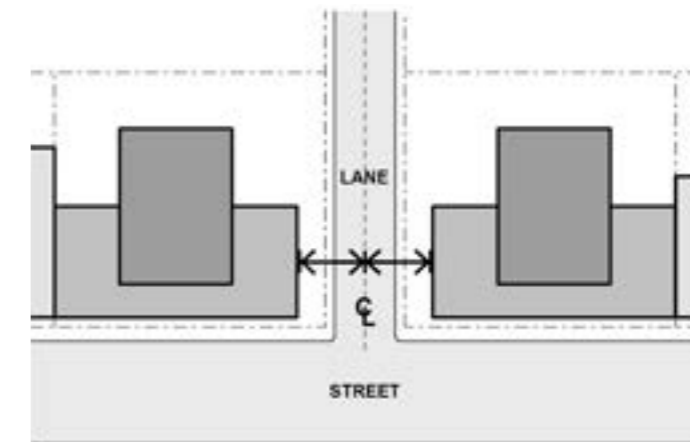

Access to daylight is concerned largely with how much daylight enters a room, regardless of orientation and the sun's path through the sky. Access to sunlight is different, as it is concerned solely with how much of the sun's path through the sky can be seen from windows within the room and is dependent on orientation.

- 1 Establish building setbacks to respond to the existing or preferred urban context.
 → GUIDANCE: Every site has unique characteristics and will require a site specific design response to building setbacks.

Site characteristics which influence setbacks may include:

- Site orientation
- Scale and type of surrounding buildings
- Existing or preferred future patterns of building setbacks
- Site features such as existing significant vegetation
- Important view lines such as towards heritage buildings
- Offsite impacts such as overshadowing and noise

→ GUIDANCE: Refer to relevant Local Planning Policies and any local planning provisions for preferred and mandatory minimum setbacks.

- 2 Establish setbacks to adjacent buildings and uses to ensure adequate amenity.
 → GUIDANCE: Take account of existing buildings and uses on adjoining sites and their potential for future development when establishing building setbacks

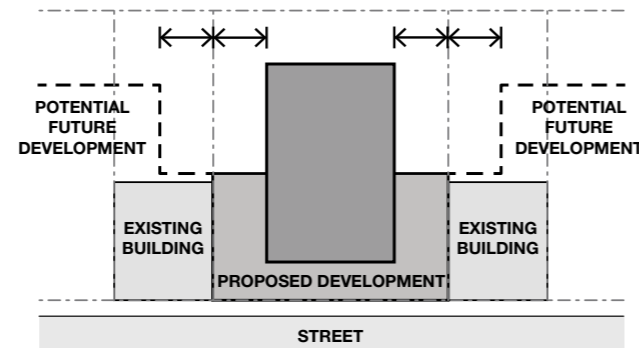

Plan diagram. Adjoining sites and the preferred future development potential help to inform appropriate building setbacks.

- 3 Establish the street frontage setback alignment of buildings to contribute to the character and amenity of the public realm.
 → GUIDANCE: Refer to relevant Local Planning Policies and any local planning provisions for preferred and mandatory street frontage setback requirements.
 → GUIDANCE: Refer to the Urban Design Guidelines for Victoria or relevant local design guidelines when determining appropriate front setbacks.

- 4 Establish internal setbacks to achieve daylight, privacy and outlook objectives between dwellings within a site.
 → GUIDANCE: Internal setbacks can be determined using a similar method as setbacks from site boundaries.

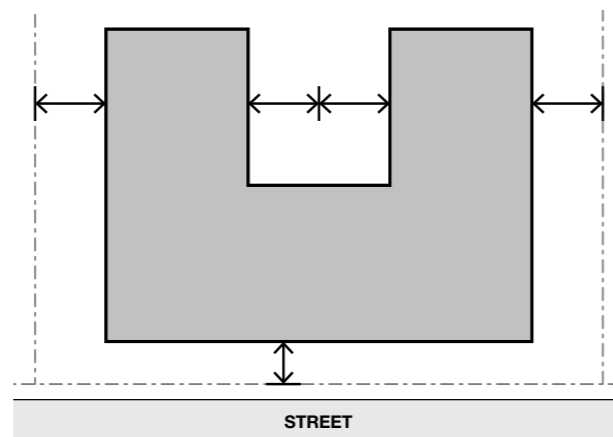

Plan diagram. Setbacks between dwellings achieve amenity objective.

- 5 In streets where buildings have zero side setback, such as in dense urban contexts, main streets or for podium forms within centres, continue the built form pattern.
 → GUIDANCE: The extent of walls on boundaries may be informed by the relevant planning provisions, the pattern of building types within the context and amenity impact on adjoining properties.

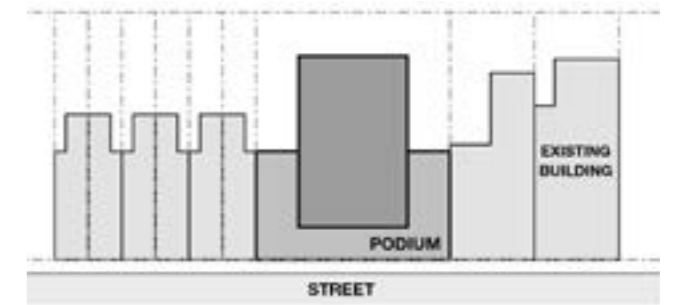

Plan diagram. Side setbacks at lower levels may not be required in some urban contexts.

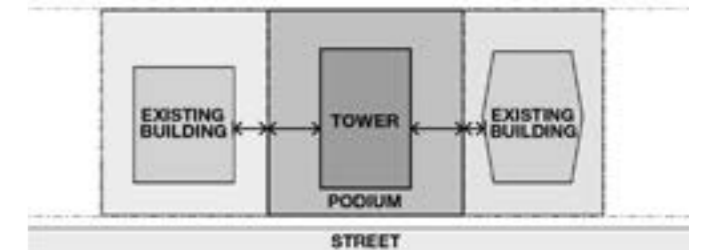

- 6 Provide side setbacks in contexts where they contribute to the landscape character of the street.
 → GUIDANCE: Gaps between buildings allow views through to vegetation along the side and to the rear of buildings.

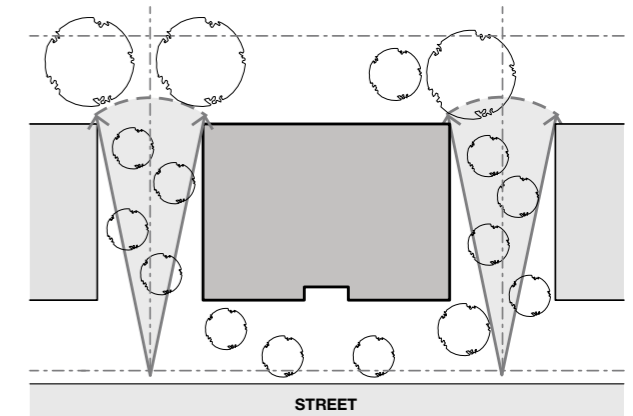

Plan diagram. Setbacks contribute to a landscape character.

- 7 Typically, on narrow infill sites, minimise side setbacks and face habitable rooms towards the street and the rear of the site.
- GUIDANCE: Avoiding outlook towards the side of narrow sites, optimises amenity and privacy between buildings.

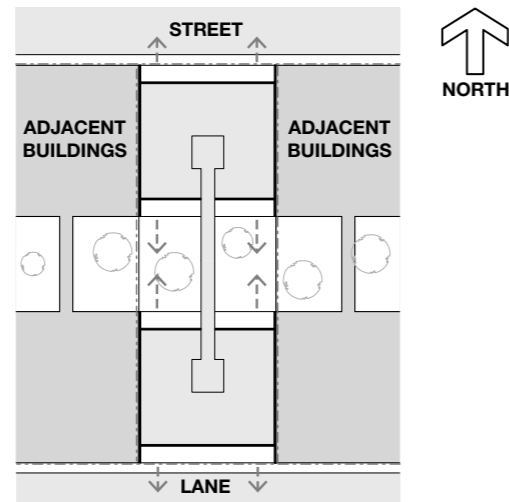

Plan diagram. Direct habitable rooms on narrow sites to optimise internal amenity.

- 8 Where habitable spaces and balconies face towards side boundaries, increase side setbacks to allow access to daylight and outlook, while maintaining privacy.

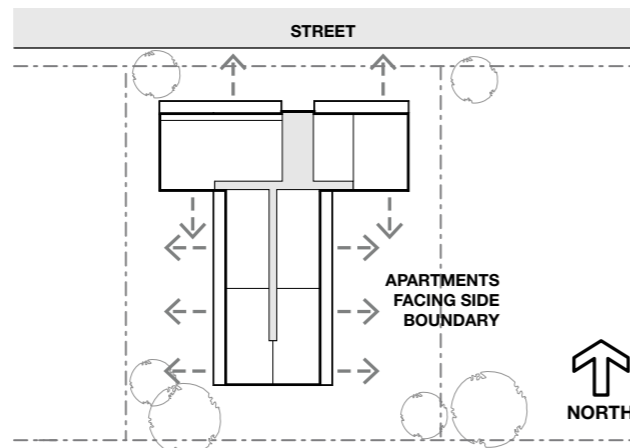

Plan diagram. Dwelling aspect informs side setback requirements.

- 9 Where contexts allow for buildings in landscaped areas, configure the building setbacks to retain existing mature trees and to accommodate deep soil areas.
- GUIDANCE: Appropriate building setbacks will assist in meeting the landscaping standard.

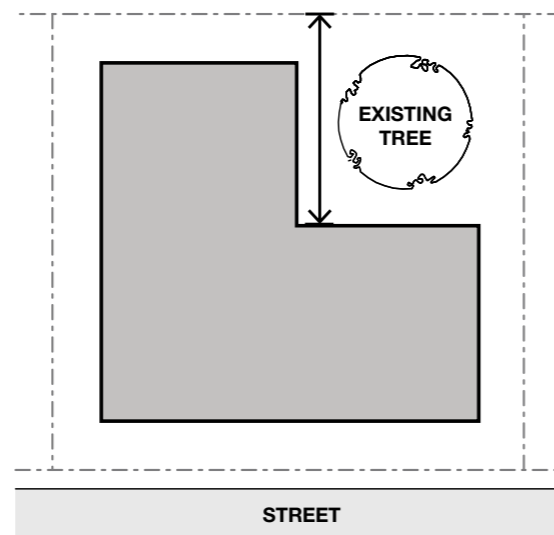

Plan diagram. Setbacks can accommodate deep soil areas and existing landscaping.

- 10 Ensure building setback is responsive to the adjoining building form and height to deliver adequate daylight, privacy and outlook for dwellings.
- GUIDANCE: Where the height of a building increases, setbacks should typically increase to achieve adequate amenity and good built form outcomes.

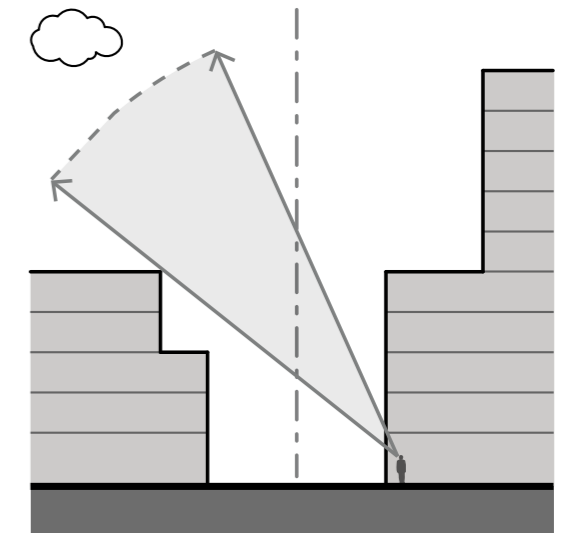

Section diagram. Setbacks typically increase with building height.

- 11 Avoid use of lightwells as the primary source of daylight to a habitable room.
- GUIDANCE: Lightwells should only be considered as a secondary source of daylight to living rooms.
- 12 Use building setbacks and the relationship between buildings on a site, as the primary method of limiting views into habitable room windows and private open spaces.
- GUIDANCE: Adjust building form, façade shape and window locations to further limit views into habitable room windows and private open spaces while protecting access to daylight and outlook.

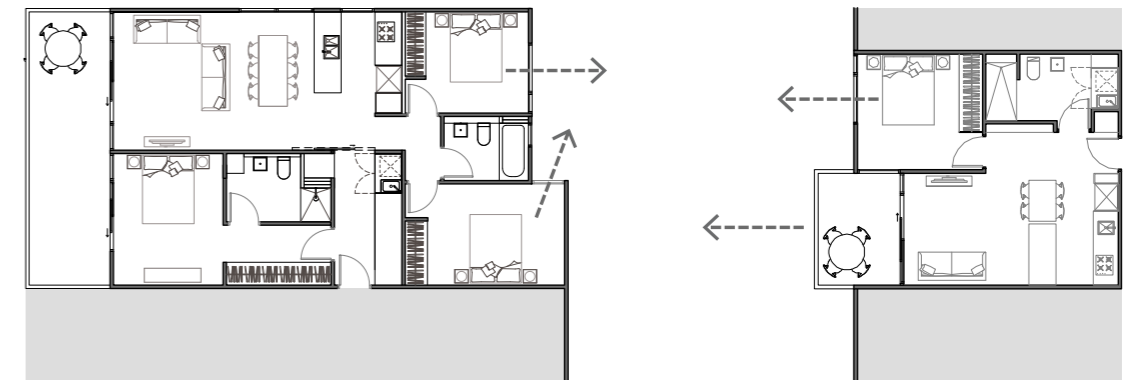

Plan diagram. Building form and facade shape can assist to limit direct views.

12 → GUIDANCE: In addition to building setbacks, design techniques for privacy include:

- Creating oblique and controlled views such as bay windows.
- Limiting lengths of facades that direct views towards the adjoining habitable rooms and private open spaces by shaping, staggering or realigning facades.
- Using sill and balustrade heights and depths to limit direct views downwards.
- Using pergola and shading devices to screen views to dwellings and private open spaces on lower levels.

→ GUIDANCE: These techniques limit views without compromising access to daylight, natural ventilation and outlook.

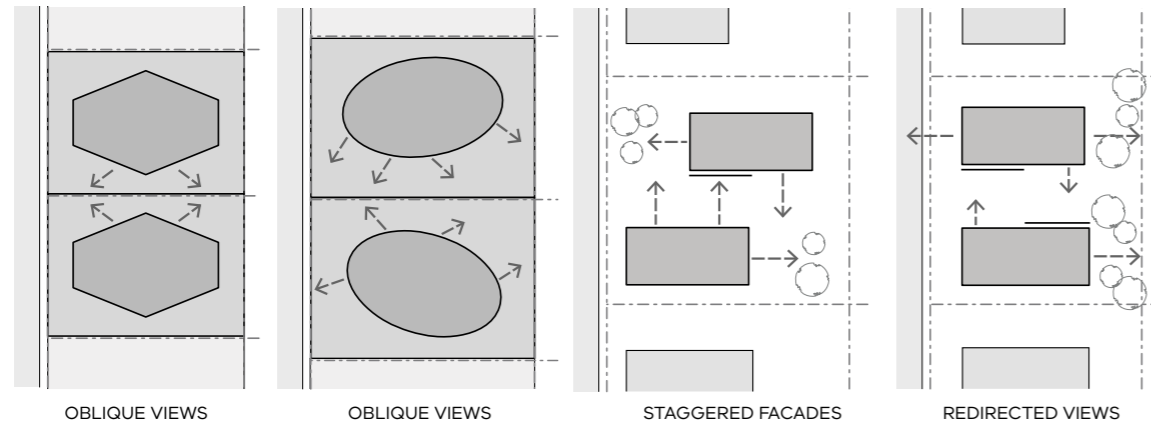

Plan diagram. Shaping, staggering and realigning facades can assist in limiting direct views.

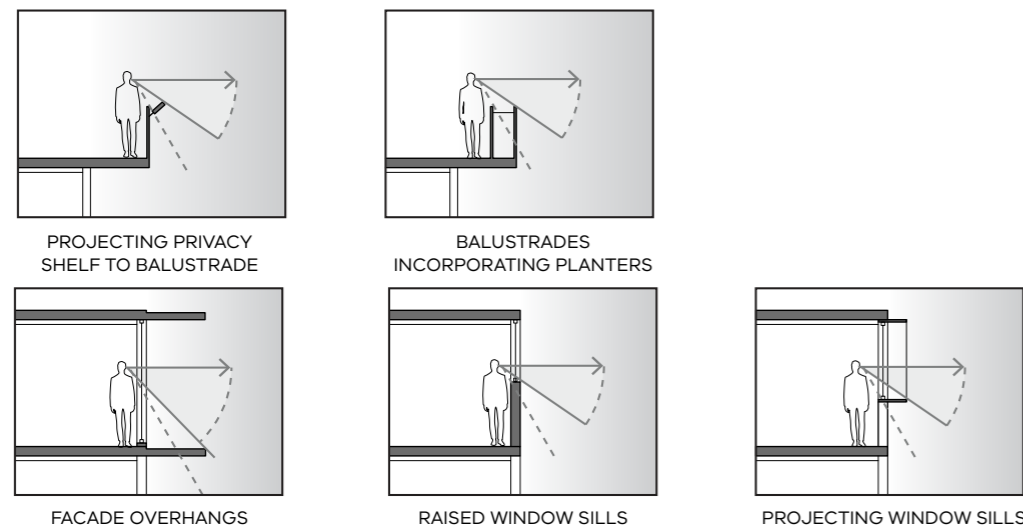

Section diagram. Design techniques to assist in limiting direct downward views.

13 When habitable room windows and private open spaces in separate dwellings directly face each other, generally provide greater building separations than where one dwelling faces the side of another dwelling.



Plan diagram. Dwelling aspect informs setbacks.

14 Arrange building setbacks to control direct views into habitable room windows or private open spaces from public and communal spaces, other uses or dwellings.

→ GUIDANCE: Avoid the need for screens or opaque glass that restrict views into public spaces

15 Use building setbacks to provide outlook and a visual connection from a dwelling to its context and allowing for visual relief.

→ GUIDANCE: Greater building separation is required to achieve adequate outlook where there is not a strong connection to the street or ground such as between apartment towers.

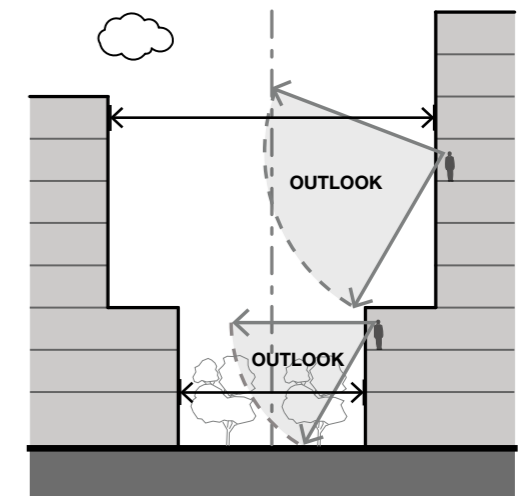

Section diagram. Quality of outlook informs building setback.

Supporting documentation

Nominate all minimum building setbacks.

Guidance to communal open space

Why this is important

Communal open space helps improve people’s mental and physical health. In well-designed, accessible, communal open space, individuals, families and communities can exercise, play and relax. They are places that neighbours can socialise and build relationships including through activities like gardening and entertaining. They can also help increase perceptions of safety, with more people keeping an eye out for others.

Application

Clause 55.07-2 (Communal open space) applies to apartment developments of four storeys or less (excluding a basement).

Clause 58.03-2 (Communal open space) applies to apartment developments of five or more storeys (excluding a basement) in a residential zone and all apartment developments in other zones.

Communal open space objective (Clause 58.03-2 or Clause 55.07-2)

To provide communal open space that meets the recreation and amenity needs of residents.

To ensure that communal open space is accessible, functional, and is easily maintained.

To ensure that communal open space is integrated with the layout of the development and enhances resident amenity.

Standard (D7 or B36)

A development of 10 or more dwellings should provide a minimum area of communal outdoor open space of 30 square metres.

If a development contains 13 or more dwellings, the development should also provide an additional minimum area of communal open space of 2.5 square metres per dwelling, or 220 square metres. This additional area may be indoors or outdoors and consist of multiple separate areas of communal open space.

Each area of communal open space should be:

- Accessible to all residents.
- A usable size, shape and dimension.
- Capable of efficient management.
- Located to:
 - Provide passive surveillance, where appropriate.
 - Provide outlook for as many dwellings as practicable.
 - Avoid overlooking into habitable rooms and the private open space of new dwellings.
 - Minimise noise impacts on new and existing dwellings.

Any area of communal outdoor open space should be landscaped and include canopy cover and trees.

Decision guidelines

Before deciding on an application, the responsible authority must consider:

- Any relevant urban design objective, policy or statement set out in this planning scheme.
- The design response.
- The availability of and access to public open space.

Design guidance

Interpreting the standard

Every development of 10 or more dwellings should provide a minimum area of landscaped communal outdoor open space of 30 square metres. The intention is to provide for residents shared space that accommodates a canopy tree for shade and cooling, or at least a pergola covered by climbing plants.

Developments of 13 or more dwellings need to also provide an additional 2.5 metres of communal open space, in addition to the 30 square metres of landscaped outdoor communal open space.

Calculate the additional communal open space by subtracting the number 12 from the total number of dwellings and then multiply that number by 2.5 metres

The additional communal open space can be indoor or outdoor communal open space.

The total combined area of communal open space can consist of multiple separate areas.

The table below summaries the communal open space requirements for a range of developments.

Table 1: Communal open space requirement

Number of dwellings	Minimum area of landscaped communal outdoor open space	Minimum area of communal open space	Total minimum area of communal open space
10	30 square metres	nil	30 square metres
13	30 square metres	2.5 square metres (1 x 2.5 metres)	32.5 square metres
50	30 square metres	95 square metres (38 x 2.5 metres)	125 square metres
100 or more	30 square metres	220 square metres (88 x 2.5 metres) (maximum requirement reached)	250 square metres (maximum requirement reached)

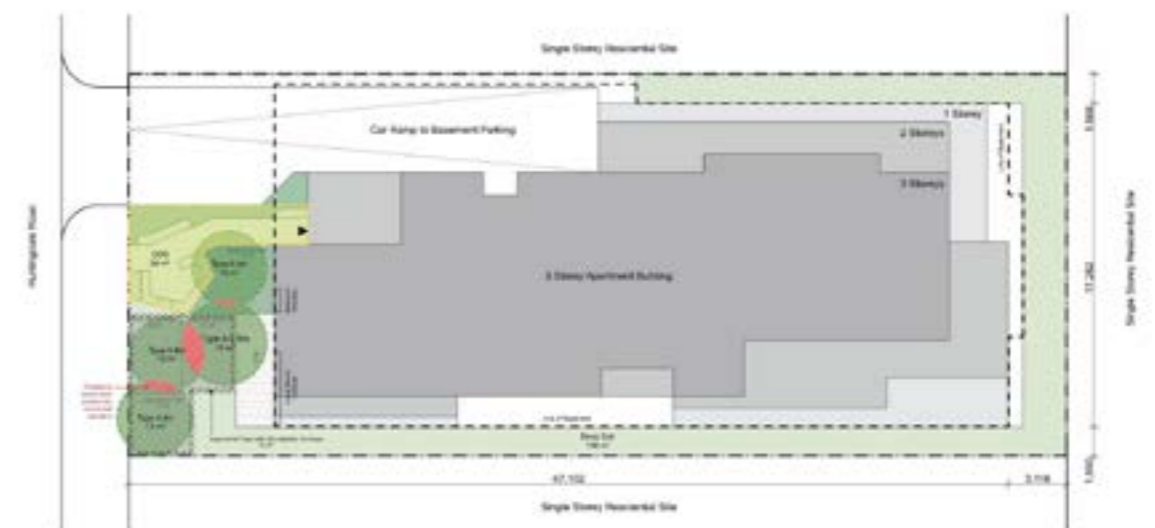

Landscaped outdoor communal open space can be provided in the front setback as appropriate to the urban context.

About outdoor communal open space

Outdoor communal open space:

- is communal open space which is external to a building and has been set aside within the development for use by occupants. It can be provided in multiple places in an apartment development
- provides amenity for residents by accommodating canopy trees, productive gardens and other types of landscaping, access to outlook and sunlight and access to seating and a variety of communal outdoor recreation facilities for all ages
- is also distinct from private open space, common areas, service access areas and indoor communal spaces. These areas do not contribute to the minimum provision of outdoor communal open space. Common areas include circulation corridors, an entry lobby, outdoor pathways, waste rooms, car parking, bike storage, light courts and private gardens located within building setbacks
- can incorporate outdoor circulation spaces or pathways, provided these are functionally integrated with the outdoor communal open space and support the creation of comfortable gathering spaces
- can be located on rooftops, podiums, at the ground floor in setbacks from boundaries or in ground-level courtyards. The siting and design of communal open space should relate to the context of the site and the typology of the development.

1 Provide a communal open space that enables a comfortable outdoor area for residents' recreation.

→ DESIGN IDEAS: To enable a comfortable outdoor communal open space that is useable throughout the year and in a range of weather conditions, ideas include:

- Orientating the space to the north of the site to benefit from solar access
- Locating the space off a multi-purpose recreation room
- Planting a mix of deciduous and evergreen vegetation, especially canopy trees
- Implementing pergolas and fixed shading devices
- Providing wind protection via hard and soft landscaping
- Co-locating with communal open space on neighbouring sites to enable the clustering of trees and vegetation.

→ GUIDANCE: Outdoor communal open space, particularly at podiums or rooftops, should be protected from strong winds.



Hawke + King apartments, West Melbourne

The interior, landscaped, communal open space provides shared open space and allows for dual-aspect apartments.

Architect: Six Degrees Architects. Landscaping: TNLA Landscape Architects. Photo: Greg Elms.



Arkadia Apartments, Alexandria, NSW

This communal open space is on a roof terrace.

Architect and landscaping: Breathe Architecture, DKO Architecture and Oculus. Photo: Tom Ross.

2 **Facilitate convenient access to outdoor communal open space.**

- DESIGN IDEAS: To provide conveniently located outdoor communal open space, ideas include:
- A designated area with seating and landscaping within the street setback adjacent to the building entry
 - A green common or linear courtyard with individual access from private open space to dwelling entries
 - A centrally located courtyard accessed from a lobby or common area
 - A rooftop garden adjacent to shared amenities.
- GUIDANCE: Ideally, make communal open space visible from circulation areas.
- GUIDANCE: Provide convenient access to landscaping and furniture for maintenance.
- GUIDANCE: If a site is located next to a public park, consider the accessibility and functionality of the park in determining the size and type of the development's communal open space.



Nightingale 1, Brunswick

The communal open space is adjacent to shared amenities

Architect: *Breathe Architecture*. Photo: *Tom Ross*.



9 Smith Street, Fitzroy

The communal open space is in a light court accessed from a lobby.

Architect: *MAArchitects*. Photo: *Derek Swalwell*.



Cantala Apartments, Caulfield North

The communal open space is along a pathway between apartment buildings.

Architect: *Tristan Wong, SJB Architects*. Landscape: *Jack Merlo*. Photo: *Aaron Puls*.

3 Integrate canopy trees and landscaping to provide summer shade and habitat to outdoor areas.

- GUIDANCE: Canopy trees should be provided in communal open space. Where canopy trees cannot be provided, implement pergolas or similar structures with climbing plants as per landscaping requirements.
- GUIDANCE: Supplementary landscaping should be provided in communal open space to improve the outlook into and within the communal open space and to create a visual and noise buffer to other uses in the building.



Nightingale 2, Fairfield

Trees in raised planters integrate with a pergola structure and climbing plants on the communal roof terrace.

Architecture and landscaping: Six Degrees Architects, SBLA landscape architecture + urban design. Photo: Rory Gardiner.



Essence Apartments, Perth

Trees in raised planters are a key feature of the central communal courtyard.

Architecture and landscaping: Hames Sharley, CAPA. Photo: Douglas Mark Black.

4 Minimise adverse amenity impacts on neighbouring sites from upper-level outdoor communal open spaces.

- DESIGN IDEAS: To manage overlooking from upper-level communal open space into private open space or habitable room windows on adjacent sites, ideas include:
 - Perimeter planters comprising shrubs or other types of screening vegetation
 - Permeable balustrades or feature screens which complement the design of the building.
- GUIDANCE: Communal open space should be oriented to street frontages and/or public open space to avoid overlooking into neighbouring sites and allow for passive surveillance to the public realm.



Oxford and Peel, Collingwood

Perimeter planters have screening vegetation.

Architecture: Jackson Clements Burrows Architects. Photo: Peter Clarke.



ILK Apartments, South Yarra

Permeable balustrades and landscaping define the perimeter of the communal open space.

Architecture and landscaping: Cox Architecture, Tract Consultants. Photo: Robyn Oliver.

5 Support passive surveillance while protecting the amenity of dwellings within the site.

→ DESIGN IDEAS: To enable passive surveillance and green outlooks to communal open spaces while maintaining visual privacy for dwellings on-site, ideas include:

- Raised planters or low, permeable fencing from ground-level dwellings and private open space
- Operable external blinds or screens to habitable room windows, to enable flexibility in outlook and privacy.



Arkadia Apartments, Alexandria, NSW

Raised planters and low fencing separate private and communal open space.

Architect and landscaping: Breathe Architecture, DKO Architecture and Oculus. Photo: Tom Ross.

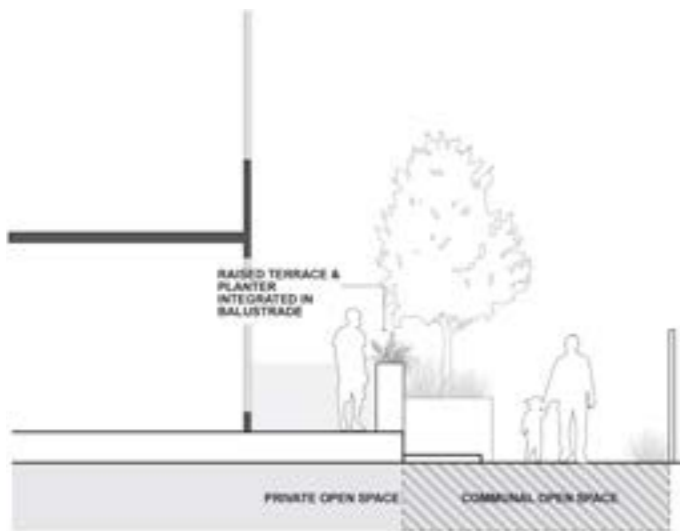

Separating communal and private open space

Communal open space and private open space are separated, maintaining passive surveillance and outlook.

6 Create a useful and attractive outdoor communal open space that can accommodate a range of activities.

→ DESIGN IDEAS: To create useful and attractive outdoor communal open spaces, ideas include:

- A mix of seating areas to enable flexible social interaction
- Productive or communal gardens
- Barbecue facilities and outdoor dining
- Playgrounds and other spaces suitable for children to play
- Outdoor gym equipment and/or sporting facilities
- Lighting to enable the space to be used by day and night.

→ GUIDANCE: Outdoor communal open space should accommodate access and activities for people of all ages and abilities.

→ GUIDANCE: Communal open space should be protected from visible or noisy building services.

→ GUIDANCE: Communal open space should accommodate facilities for maintenance and storage and a hose point.

→ GUIDANCE: Furniture, materials and surface finishes should be robust and easily maintained, to preserve the longevity of the space.

→ GUIDANCE: Avoid light spill into apartment windows and private open space from lighting within communal open space



Nightingale 1, Brunswick

This rooftop terrace comprises seating areas and shade structures.

Architect and landscaping: Breathe Architecture, Oculus. Photo: Tom Ross.



Nightingale 1, Brunswick

This rooftop terrace includes productive gardens.

Architect and landscaping: Breathe Architecture, Oculus. Photo: Tom Ross

Guidance to solar access to communal outdoor open space

Why this is important

Providing good solar access to communal open space ensures these spaces are desirable and usable for residents. Well-designed communal outdoor open spaces are used more frequently and support a sense of community.

Application

Clause 55.07-3 (Solar access to communal open space) applies to apartment developments of four storeys or less (excluding a basement).

Clause 58.03-3 (Solar access to communal outdoor open space) applies to apartment developments of five or more storeys (excluding a basement) in a residential zone and all apartment developments in other zones.

Solar access to communal outdoor open space objective (Clause 58.03-3 or Clause 55.07-3)

To allow solar access into communal outdoor open space.

Design guidance

Interpreting the Standard

The minimum of two hours of sunlight does not need to be a continuous two-hour duration.

Where the communal open space is provided in multiple locations, then the solar access requirement applies to the primary space.

Where the proposal includes more than one area for communal open space, the primary communal open space should be a minimum of 50 percent of the total consolidated area.

- 1 Locate communal open space in areas that will have minimal overshadowing from surrounding buildings.

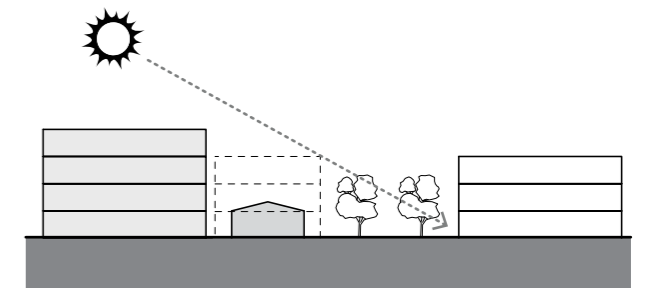

Section diagram. Locate communal open space to have minimal overshadowing

- 2 When locating communal open space to achieve winter sun, also select the location to provide usability and amenity.
 - GUIDANCE: Rooftop communal open spaces provide opportunity for good solar access, however, they require careful design to prevent undesirable exposure to wind, rain and heat during summer.

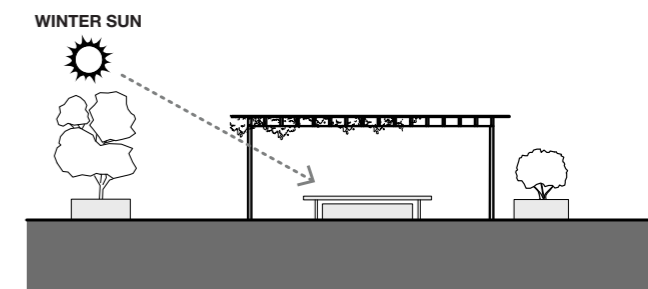

Section diagram. Locate communal open space to have minimal overshadowing

Supporting documentation

Provide shadow diagrams for the communal open space for June 21 to demonstrate existing solar access, and any future overshadowing potential.

Guidance to landscaping

Why this is important

Landscaping establishes the presence of nature in a development, providing places to enjoy the fresh air and shade during the warmer months and year-round calming effects shown to improve creativity and comfort and reduce depression, anxiety and stress. Canopy trees, plants and other greenery consume carbon dioxide; reduce stormwater runoff; make cities cooler, greener and more water-sensitive; provide habitat for native species; and soften the visual impact of apartment buildings.

Application

Both Clause 55.07-4 (Landscaping) applies to apartment developments of four storeys or less (excluding a basement).

Clause 58.03-5 (Landscaping) applies to apartment developments of five or more storeys (excluding a basement) in a residential zone and all apartment developments in other zones.

Landscaping objectives (Clause 58.03-5 or Clause 55.07-4)

To provide landscaping that supports the existing or preferred urban context of the area and reduces the visual impact of buildings on the streetscape.

To preserve existing canopy cover and support the provision of new canopy cover.

To ensure landscaping is climate responsive, supports biodiversity, wellbeing and amenity and reduces urban heat.

Standard (D10 or B38)

Development should retain existing trees and canopy cover.

Development should provide for the replacement of any significant trees that have been removed in the 12 months prior to the application being made.

Development should:

- Provide the canopy cover and deep soil areas specified in [Table D2](#). Existing trees can be used to meet the canopy cover requirements of [Table D2](#).
- Provide canopy cover through canopy trees that are:
 - Located in an area of deep soil specified in [Table D3](#). Where deep soil cannot be provided trees should be provided in planters specified in [Table D3](#).
 - Consistent with the canopy diameter and height at maturity specified in [Table D4](#).
 - Located in outdoor communal outdoor open space or common areas or street frontages.
- Comprise smaller trees, shrubs and ground cover, including flowering native species.
- Include landscaping, such as climbing plants or smaller plants in planters, in the street frontage and in outdoor areas, including outdoor communal open space.
- Shade outdoor areas exposed to summer sun through landscaping or shade structures and use paving and surface materials that lower surface temperatures and reduce heat absorption.
- Be supported by irrigation systems which utilise alternative water sources such as rainwater, stormwater and recycled water.
- Protect any predominant landscape features of the area.
- Take into account the soil type and drainage patterns of the site.
- Provide a safe, attractive and functional environment for residents.
- Specify landscape themes, vegetation (location and species), irrigation systems, paving and lighting.

Table D2 Deep soil areas and deep soil requirements

Site area	Canopy cover	Deep soil
1000 square metres or less	5% of site area Include at least one Type A tree	5% of site area or 12 square metres whichever is greater
1001 – 1500 square metres	50 square metres plus 20% of site area above 1000 square metres Include at least one Type B tree	7.5% of site area
1501 - 2500 square metres	150 square metres plus 20% of site area above 1,500 square metres Include at least two Type B trees or one Type C tree	10% of site area
>2500 square metres	350 square metres plus 20% of site area above 2500 square metres Include at least two Type B trees or one Type C tree	15% of site area

Table D3: Soil requirements for trees

Tree type	Tree in deep soil	Tree in planter	
	Area of deep soil	Volume of planter soil	Depth of planter soil
A	12 square metres (min. plan dimension 2.5 metres)	12 cubic metres (min. plan dimension of 2.5 metres)	0.8 metres
B	49 square metres (min. plan dimension 4.5 metres)	28 cubic metres (min. plan dimension of 4.5 metres)	1 metre
C	121 square metres (min. plan dimension 6.5 metres)	64 cubic metres (min. plan dimension of 6.5 metres)	1.5 metres

Note: Where multiple trees share the same section of soil, the total required amount of soil can be reduced by 5% for every additional tree, up to a maximum reduction of 25%.

Table D4: Tree types and sizes

Tree type	Minimum canopy diameter at maturity	Minimum height at maturity
A	4 metres	6 metres
B	8 metres	8 metre
C	12 metres	12 metres

Decision guidelines

Before deciding on an application, the responsible authority should must consider:

- Any relevant neighbourhood character, landscaping or environmental policy, objective, strategy or statement set out in this planning scheme.
- The design response.
- The health of any trees to be removed.
- The suitability of the proposed location, deep soil area and planter soil volume for canopy trees.
- The suitability of the proposed landscaping in outdoor communal outdoor open space.
- The type and quantity of canopy cover, including any alternatives to trees.
- The soil type and drainage patterns of the site.
- The ongoing management of landscaping, including any irrigation systems.

Design guidance

Interpreting the standard

Designing the landscaping should be an integral part of a development’s design and planning phase, rather than an after-thought when space for landscaping and solar access is constrained.

The standard focuses on the provision of canopy cover. [Table A](#) details what ‘canopy cover’ includes and does not include.

The following is a suggested method to meet the standard’s requirements.

Step	Method
1	Ensure a suitably qualified professional designs the landscaping of the apartment development.
2	Work with a landscape architect and commission an arborist report to ascertain which existing canopy trees are high-quality and should be retained. Existing trees can count toward the canopy cover requirement: Table D4 shows tree types and sizes and Table D2 canopy cover and deep soil requirements.
3	Where existing trees will be retained on-site and on adjoining land and require protection, nominate a tree protection zone in the arborist’s report. Keep basements and all storeys of the building clear of the tree protection zone.
4	Architects and building designers can calculate the space requirements for canopy trees and deep soil, using the steps below.

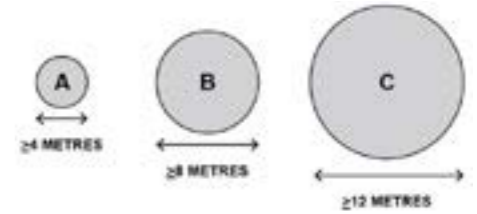
Step	Example
a) Determine the site area	The example site is 1,501 square metres
b) Calculate the square meterage of canopy cover required (using Table D2 , column 2)	The site requires 150 square metres plus 20% of the site area above 1,500 square metres which is: 150 square metres + (1*.2) = 150.2 square metres
c) Determine the canopy tree requirement (using Table D2 , column 2)	A 1,501 square metre site requires at least two Type B trees or one Type C tree
d) Determine the canopy tree plan dimensions (using Table D4 , column 2)	The image below shows the dimensions diagrammatically 
e) Determine the size of canopy trees needed to achieve the required canopy cover (using Table B) If trees are located close together, any area of canopy overlap must be counted only once when calculating canopy cover	a) 150.2 square metres of canopy cover is required (from step 2) b) The site requires at least two Type B trees or one Type C tree (from step c) c) Two Type B canopy trees of 8–8.9 metres will provide at least $50.3*2 = 100.6$ square metres mature canopy cover area (using Table B) d) Two Type A canopy trees of 6–6.9 metres will provide at least $28.3*2 = 56.6$ square metres mature canopy cover area (using Table B) ... thus providing $100.6+56.6 = 157.2$ square metres mature canopy cover area and so satisfying the requirement
f) Determine the deep soil area required (using Table D2) Deep soil is an area of natural or newly prepared ground with no structure located below or above it	A 1501 square metre site requires 10% of the site (150.1 square metres) to be deep soil area

Step	Method				
	<table border="1"> <thead> <tr> <th>Step</th> <th>Example</th> </tr> </thead> <tbody> <tr> <td>g) If canopy trees are to be clustered in the same area of soil, the total area of soil required can be reduced (as per the note in the standard) by 5% for every additional canopy tree up to a maximum of 25% soil reduction for six or more canopy trees. The minimum dimensions and depth for the soil are based on what is required for the largest canopy tree in the cluster.</td> <td>Use Table E to determine the soil reduction</td> </tr> </tbody> </table>	Step	Example	g) If canopy trees are to be clustered in the same area of soil, the total area of soil required can be reduced (as per the note in the standard) by 5% for every additional canopy tree up to a maximum of 25% soil reduction for six or more canopy trees. The minimum dimensions and depth for the soil are based on what is required for the largest canopy tree in the cluster.	Use Table E to determine the soil reduction
Step	Example				
g) If canopy trees are to be clustered in the same area of soil, the total area of soil required can be reduced (as per the note in the standard) by 5% for every additional canopy tree up to a maximum of 25% soil reduction for six or more canopy trees. The minimum dimensions and depth for the soil are based on what is required for the largest canopy tree in the cluster.	Use Table E to determine the soil reduction				
5	<p>Locate the required (new and existing) canopy trees during the initial design analysis and in consultation with the landscape architect. Locate canopy trees:</p> <ul style="list-style-type: none"> where they will receive solar access (as they will perform better) within deep soil areas (as they will have access to groundwater and nutrients) in areas of outdoor communal open space or other outdoor common areas (where they will have more permanence), then in areas of private open space <p>Plan the form of the development around the location of these canopy trees, as well as any requirements for setbacks from boundaries and allocations for communal or private open space.</p> <p>If deep soil areas are not available, use constructed planters recessed into the building structure at the ground, podium or rooftop levels. Use Table D3 to determine planter sizes.</p> <p>If there is a risk of instability due to wind (especially on rooftop and podium terraces), anchor trees in planters, as in the illustration.</p> <p>The ground surface around trees should be permeable. A solid pavement should not encroach more than 1.2 metres into the tree protection zone and be on non-compacted soil.</p> <p>There is further information about soil space requirements in:</p> <ul style="list-style-type: none"> Table B: Deep soil area requirements for canopy trees Table C: Planter soil volume requirements for canopy trees 				
6	<p>If climbing plants are to be used to provide canopy cover and be in a planter, provide sufficient volumes of soil to ensure the plant can spread to cover the pergola structure. Use Table D to determine the size of planters for climbing plants on vertical or horizontal surfaces.</p>				

Table A: Canopy cover inclusions and exclusions

Canopy cover includes	Canopy cover does not include
<ul style="list-style-type: none"> The area of the canopy of an existing retained tree on the site that provides effective shade and shelter for people The area of the mature canopy of a new canopy tree to be planted within the title boundary of the site The area of the mature canopy of a new canopy tree planted in a raised planter Where canopy trees are not provided, canopy cover can comprise the area covered by climbing plants on a pergola with a minimum clear height of 2.4 metres 	<ul style="list-style-type: none"> Built structures (such as roofs, eaves, awnings and roofed or textile-covered shade structures) Areas of open built structures that do not have coverage by climbing plants Ground covers, shrubs and climbing plants on vertical surfaces including green walls or green façades Any tree or plant that cannot provide effective shade or shelter for a person A tree planted outside the title boundary of the subject site including on public land Any area of canopy cover below a cantilevered or overhanging built form or structure Any area of canopy cover that overlaps with the canopy of another tree that has already been included in the calculation of canopy cover

Note: Areas of canopy cover provided by mature canopy trees are described in Table B below.

Table B: Deep soil area requirements for canopy trees

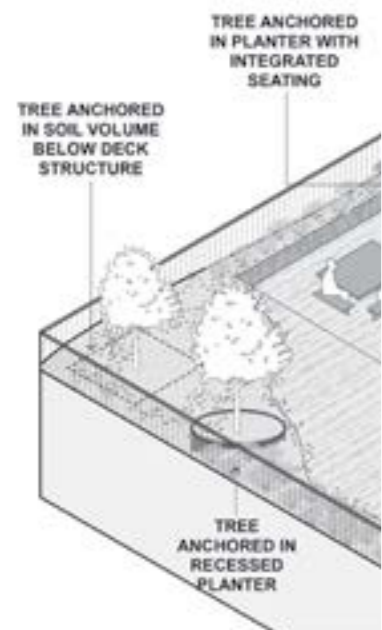
Tree Size	Mature canopy diameter ¹	Mature canopy cover area	Minimum deep soil area required	Minimum soil plan dimension
TYPE A	4–4.9 metres	12.6–19.6 square metres	12 square metres	2.5 metres
	5–5.9 metres	19.7–28.2 square metres	16 square metres	3 metres
	6–6.9 metres	28.3–38.4 square metres	25 square metres	3.5 metres
	7–7.9 metres	38.5–50.2 square metres	36 square metres	4 metres
TYPE B	8–8.9 metres	50.3–63.5 square metres	49 square metres	4.5 metres
	9–9.9 metres	63.6–78.4 square metres	64 square metres	5 metres
	10–10.9 metres	78.5–94.9 square metres	81 square metres	5.5 metres
	11–11.9 metres	95.0–113.0 square metres	100 square metres	6 metres
TYPE C	12–12.9 metres	113.1–132.6 square metres	121 square metres	6.5 metres
	13–13.9 metres	132.7–153.8 square metres	136 square metres	7 metres
	14 metres and greater	Above 153.9 square metres	144 square metres	7.5 metres

Note

¹ If using the radius rather than the diameter to calculate the mature canopy cover area, use the formula $area = 3.14 * r^2$: the radius is half the diameter. For example, for a diameter of 4 metres, use $area = 3.14 * 2^2 = 12.56$.

Table C: Planter soil volume requirements for canopy trees

Tree Size	Mature canopy diameter	Minimum required planter soil volume ¹	Minimum soil plan dimension	Minimum planter soil depth ¹
TYPE A	4m–4.9 metres	7.54 cubic metres	2.5 metres	0.8 metres
	5m–5.9 metres	11.78 cubic metres	3 metres	0.8 metres
	6m–6.9 metres	16.96 cubic metres	3.5 metres	0.8 metres
	7m–7.9 metres	23.09 cubic metres	4 metres	0.8 metres
TYPE B	8m–8.9 metres	30.16 cubic metres	4.5 metres	1.0 metres
	9 metres–9.9 metres	38.17 cubic metres	5 metres	1.0 metres
	10m–10.9 metres	47.12 cubic metres	5.5 metres	1.0 metres
	11m–11.9 metres	57.02 cubic metres	6 metres	1.0 metres
TYPE C	12m–12.9 metres	67.86 cubic metres	6.5 metres	1.5 metres
	13m–13.9 metres	79.64 cubic metres	7 metres	1.5 metres
	14m and greater	92.36 cubic metres	7.5 metres	1.5 metres

Notes

1. To calculate the required soil volume for a planter, use the formula $\text{Soil required in cubic metres} = \text{Canopy cover area}$. For example, for a canopy tree with a mature diameter of 7 metres, soil required = (from [Table B](#) column 3) $38.5 \times 6 = 23.1$ cubic metres.

2. The minimum planter soil depth excludes any drainage layers provided within the planter structure.

Table D: Planter soil volume requirements for climbing plants

Canopy cover area	Minimum width of soil in planter	Maximum distance of soil from climbing plant stem	Minimum planter soil depth
< 5 square metres	450 millimetres	3 metres	450 millimetres
5–10 square metres	500 millimetres	5 metres	450 millimetres
> 10 square metres	600 millimetres	7 metres	550 millimetres

Note

Multiple climbing plants may be used to provide canopy cover. Where climbing plants are planted in the ground, use the total area of canopy cover of the climbing plants to determine the required deep soil areas.

Table E: Reduction in soil areas for clusters of trees

No. of trees	% soil reduction	Example
1	0%	a) There are two Type B canopy trees (one 11 metre & one 9 metre canopy) and one Type A (7 metre canopy) clustered in an area of deep soil
2	5%	b) These trees need 100 square metres, 64 square metres & 36 square metres of deep soil respectively (using Table B) for a total soil requirement of 200 square metres
3	10%	c) Three trees means a 10% reduction = 20 square metre reduction, so the total required soil area is 180 square metres
4	15%	d) The largest tree is 11-metre canopy, so the minimum soil plan dimension is 6 metres (using Table B)
5	20%	
6 or more	25%	

Note

Multiple climbing plants may be used to provide canopy cover. Where climbing plants are planted in the ground, use the total area of canopy cover of the climbing plants to determine the required deep soil areas.

1 Accommodate canopy trees in communal open spaces to support residential amenity.

→ DESIGN IDEAS: To create a landscaped communal open space, ideas include:

- Canopy tree planting in front setbacks where these are characteristic of the area
- A large or small courtyard with a canopy tree
- A walkway between the buildings which features canopy trees in landscaped planters.



The Eastbourne, East Melbourne

Communal open space is provided as an entry forecourt. Canopy trees are planted in raised planters, enhancing the adjacent Fitzroy Gardens.

Architect: Bates Smart. Photo: Mirvac.



Fig Tree Pocket, Newmarket, NSW

Communal open space and buildings are arranged around a significant fig tree in a courtyard.

Architect: Smart Design Studio. Image: Robert Walsh.



Assembly Apartments, North Melbourne

Communal open space is a courtyard accessed by walkways, with canopy trees in raised planters.

Architect: Woods Bagot. Photo: Trevor Mein.



Boggo Road Urban Village, Dutton Park, Qld

This building abuts a communal open space.

Architect: Cox Architecture. Photo: Christopher Frederick Jones.



9 Smith Street, Fitzroy

A canopy tree in a small courtyard can provide relief to a lift lobby or similar space on a small site.

Architect: MAArchitects. Photo: Derek Swalwell.



Front garden communal open space

In this illustration, communal open space is a front garden, with canopy trees and seating that respond to the setbacks and landscaping of the residential neighbourhood.



122 Roseneath Street, Clifton Hill

Communal open space is a walkway between the buildings with trees planted in raised planters.

Architecture and landscaping: Fieldwork, MALA Studio. Image: Tom Ross

2 Use landscaping to complement the building or street or to provide privacy.

→ DESIGN IDEAS: Where there is no significant street setback to create a landscape setting for the building, ideas include:

- Landscaping in planters at street level to separate the public realm from dwellings or private open space
- Landscaping in planters at building entries or in the front garden of ground-floor terrace dwellings
- Climbing plants on external walls or supports, planted in deep soil in a small setback or at building entries
- Landscaping in planters at upper floor levels adjacent to windows or forming part of balconies
- Landscaping in planters at the perimeter of the rooftop or podium terraces.

→ GUIDANCE: Landscaping to building frontages should be designed to last for the life of the building and be easily maintained.



Hawke + King apartments, West Melbourne

Landscaping in planters at street level provides privacy to ground floor dwellings and private open space on a busy street.

Architect: Six Degrees Architects. Landscaping: TNLA Landscape Architects. Photo: DELWP.



Hawke + King apartments, West Melbourne

The front gardens of ground-floor terrace dwellings use brickwork and planting to the street interface to mediate privacy and to scale materials to the pedestrian level.

Architect: Six Degrees Architects. Landscaping: TNLA Landscape Architects. Photo: DELWP.



Peel Street, Collingwood

Climbing plants in deep soil are used in a small setback to the street frontage.

Architect: DKO Architecture. Photo: Joel Schmetzer, Hansen Partnership.



Short Lane, Surry Hills, NSW

Planting on balconies are part of the façade.

Architect: Woods Bagot. Photo: Trevor Mein.



Fig Tree Pocket, Newmarket, NSW

Planters and visually permeable balustrades separate the public realm and the dwellings.

Architect: Smart Design Studio. Image: Robert Walsh.

3 Where canopy trees are not provided, use equivalent alternatives to provide shade and cooling.

→ DESIGN IDEA: Where canopy trees have not been used to meet the canopy cover requirements, ideas to create a landscape setting and shade for the building and paving include:

- Pergolas or similar open-framed structures covered by climbing plants on the rooftop or podium terraces.

→ GUIDANCE: Select climbing plants to ensure their suitability for the proposed locations.

→ GUIDANCE: Use [Table D](#) to determine planter soil volume requirements (and thus planter sizes) for climbing plants.



Nightingale 2, Fairfield

A pergola structure supports climbing plants on a communal rooftop.

Architecture and landscaping: Six Degrees Architects, SBLA landscape architecture + urban design. Photo: Rory Gardiner.

4 Create a landscape that develops a sense of place and is resilient to the impacts of climate change.

→ DESIGN IDEAS: To create a place that is resilient to the impacts of climate change, ideas include:

- Supplementing canopy trees or climbing plants with a variety of small trees, shrubs, lawns and ground covers that include indigenous species and flowering and fruiting varieties
- Using light-coloured paving, ground covers, lawns, raingardens and ponds in outdoor areas
- Providing light-coloured roof finishes and/or trafficable or non-trafficable green roofs
- Irrigating canopy trees and planters with water from on-site stormwater collection
- Using paving that allows water infiltration
- Providing a tap and drainage point within all outdoor areas.

→ GUIDANCE: Provide a range of functional hardscape elements to support soft landscaping (such as paths, paving, decks, fences and screens, shade structures, furniture, lighting and irrigation).



Eve Apartments, Erskineville, NSW

Climbing plants are integrated into the building façade and light-coloured paving to an outdoor area.

Architecture and landscaping: DKO Architecture, 360 Degrees Landscape Architects. Photo: Brett Boardman.



Arkadia Apartments, Alexandria, NSW

Raised garden beds are a feature of the communal open space.

Architect and landscaping: Breathe Architecture, DKO Architecture and Oculus. Photo: Tom Ross.

Supporting documentation

Architectural and landscape drawings

Architectural and landscape drawings should be consistent and demonstrate compliance with the standard. The architectural drawings need to show how the structure will accommodate the landscaping.

What architects and building designers should show on the drawings

Architectural drawings should include:

- an existing conditions site plan that locates the existing trees including trees that have been removed up to 12 months before the application
- a site plan that indicates:
 - the required canopy tree(s) including retained and proposed canopy trees and their size in diameter. Where the minimum number of canopy trees is not provided, indicate how the alternative solution provides suitable canopy cover
 - deep soil areas and planters
 - areas of outdoor communal and private open space
- sections indicating the location and dimensions of the required canopy trees, deep soil areas and planters
- a development summary table which includes:
 - the site area
 - the required canopy cover for the site
 - the number of canopy trees on the site and their size in diameter and the total amount of canopy cover provided for the site
 - the required deep soil area for the site, the amount provided and/or the planter soil volumes provided.

The landscape drawings should be prepared by a suitably qualified landscaping professional.

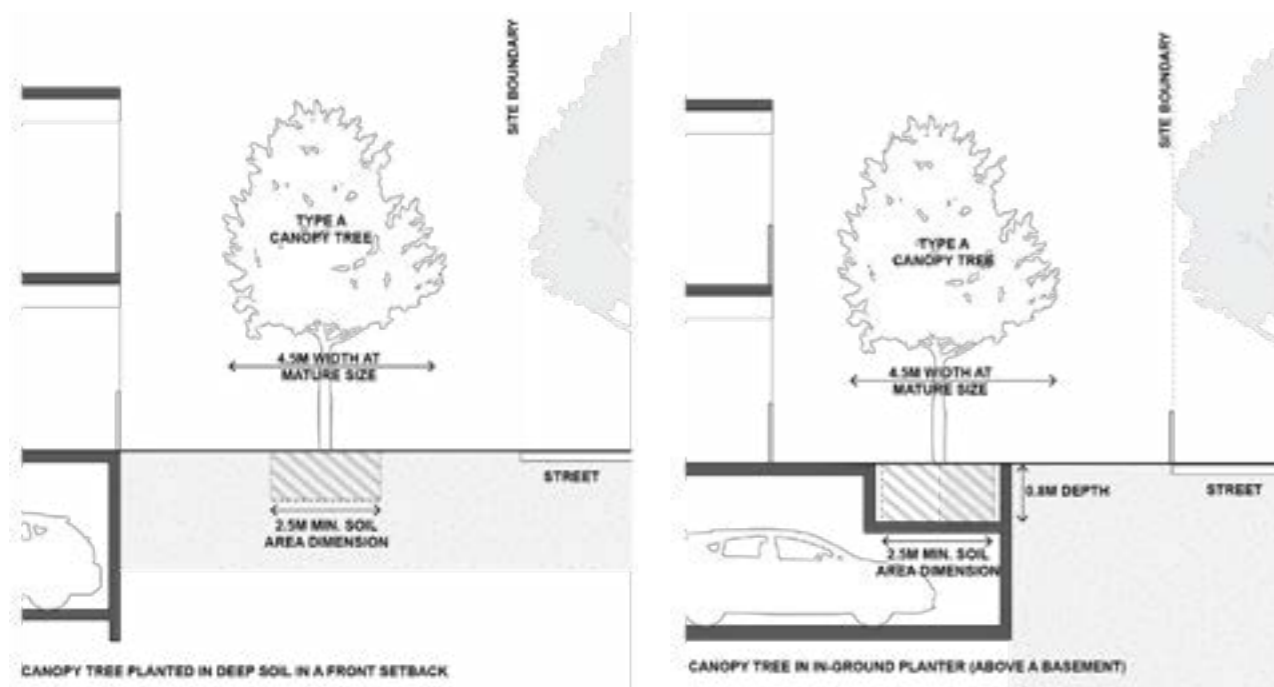
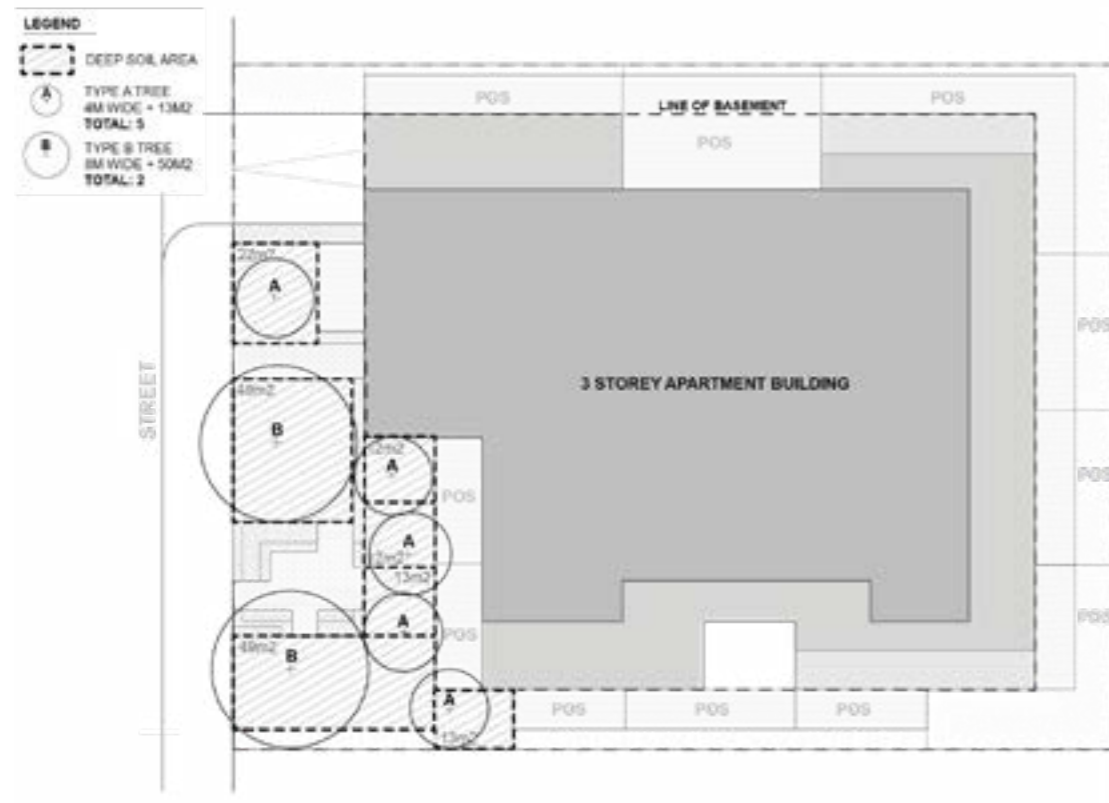

Example site plans

Canopy trees located in deep soil in a suburban context achieve the required canopy cover

What planners should look for on the drawings

Planners might:

- verify that the architectural drawings include the provision of the required canopy trees, canopy cover, deep soil areas and/or planters soil volumes
- confirm other landscaping requirements of the standard are met, such as irrigation systems.

The responsible authority should check:

- the architectural drawings are consistent with the landscape drawings
- the architectural drawings include any tree protection zone(s) and works recommended in the arborist's report
- the arborist's report and other technical reports to determine the suitability of the proposed landscaping.

Arborist's report

Provide an arborist's report where relevant, including information about removed trees (such as aerial photography or survey) and any tree protection zone(s), with details of the protection to be undertaken during construction.

Where existing trees are proposed to be retained, a tree protection zone should be nominated in an arborist's report and shown on the architectural site plan, together with details of the protection to be undertaken during construction.

Landscape maintenance management plan

The architectural and landscape drawings should consider ease of and access for maintenance.

Owners corporations should engage a suitably qualified gardener to maintain communal garden areas to ensure sound maintenance practices and consistent care.

Properly functioning irrigation systems and routine formative pruning by an arborist will be required for the life of the trees, to ensure their ongoing health and safety.

A landscape maintenance management plan (which might include a maintenance manual) may, depending on the complexity of the project, be a permit condition of the responsible authority. The following model permit condition is a guide.

Model landscape maintenance management plan permit condition

Before the development starts, a landscape maintenance management plan must be submitted to and approved by the responsible authority. Once approved, the landscape maintenance management plan will form part of the permit and must be implemented to the satisfaction of the responsible authority.

The landscape maintenance management plan must include a protocol for gaining access for maintenance purposes to privately owned land and to planting in common areas.

The endorsed landscape maintenance management plan must be implemented to the satisfaction of the responsible authority.

Guidance to external walls and materials

Why this is important

External walls create an important first and lasting — and for those who don't occupy or visit the only — impression of the building. External walls with durable materials age well over time, support the building's longevity by protecting it from the elements, minimise ongoing maintenance needs and mitigate fire risks. Ground-level facades that incorporate form, textures and colours make neighbourhoods more coherent and interesting and create pleasant experiences for pedestrians.

Application

Clause 55.07-19(External walls and materials) applies to apartment developments of four storeys or less (excluding a basement).

Clause 58.06-4 (External walls and materials) applies to apartment developments of five or more storeys (excluding a basement) in a residential zone and all apartment developments in other zones.

External walls and materials objective (Clause 58.0604 or Clause 55.07-19)

To ensure external walls use materials appropriate to the existing urban context or preferred future development of the area.

To ensure external walls endure and retain their attractiveness.

Standard (B53 or D24)

External walls should be finished with materials that:

- Do not easily deteriorate or stain.
- Weather well over time.
- Are resilient to the wear and tear from their intended use.

External wall design should facilitate safe and convenient access for maintenance.

Decision guidelines

Before deciding on an application, the responsible authority should must consider:

- Any relevant building design and urban design objective, policy or statement set out in this planning scheme.
- The urban context report.
- The design response.

Design guidance

Interpreting the standard

A basic method for selecting materials and finishes for external walls is:

- develop an urban context drawing and start the urban context report before designing the apartment building, to understand the streetscape or landscape
- decide what of the existing streetscape or landscape will be generative to the apartment building design (such as the character, form, materials and proportions of significant buildings in the area)
- select external materials that will support the performance of the building, enhance the streetscape or landscape and last for the life of the building
- explain the rationale for the building façade design and the selection of external wall materials in the design response statement.

1 Design buildings so they contribute positively to the existing urban context or build on the preferred future context of the area.

- GUIDANCE: Each site has its own characteristics that call for a design response and selection of external wall materials suitable for its location.
- DESIGN IDEAS: Contextual factors that might influence the design of external walls and the choice of materials include:
 - The materials, patterns, colours and finishes present in the surrounding area
 - Whether the area has a commercial, residential or mixed-use character
 - The landscape attributes of the area
 - Opportunities to highlight features of the surrounding area or create visual interest
 - Opportunities to influence visual perceptions of scale and mass
 - Local policies and guidelines setting out a preferred future character.
- GUIDANCE: Select robust materials that will weather well, improve with age or develop a patina and stand the test of time. Robust materials include brick, glass, steel and concrete.
- GUIDANCE: Consider the design and materials of all the external walls (including treatments for boundary walls that may be only temporarily visible) to create visual interest in the streetscape.
- GUIDANCE: External features (such as window proportions, openable windows, screen and shutters, balcony arrangements and landscaping) can be used to demonstrate the residential function of the building



35 Spring Street, Melbourne

The building's glazed façade with its integrated frame pattern responds to the Treasury Building opposite and serves to break up the mass of the elevation.

Architect: Bates Smart. Photo: Peter Clarke.



2 St Georges Road, Fitzroy North

The building's perforated metal shutters contribute to the streetscape, create visual interest and provide flexibility of outlook and privacy on this corner site.

Architect: Fieldwork. Photo: Rory Gardiner.



Holme Apartments, Collingwood

The building has an articulated brick podium and a glazed tower with shaped concrete floors. The forms and materials respond to the neighbourhood's scale and history.

Architect: John Wardle Architects. Photo: Dylan James.



Upper House Apartments, Melbourne

The bold composition of concrete walls, white glass curtain walls and projecting steel balconies add dynamism and depth to the façade and fit with the mixed-use area.

Architect: Jackson Clements Burrows. Photo: Shannon McGrath.



Whitlam Place, Fitzroy

The building's proportions and height respond to the classical stone town hall opposite, and fluted concrete and pop-out windows give depth and texture to the façade.

Architect: Freadman White in collaboration with Anon Studio. Photo: Gavin Green.

2 Design ground-level facades so they contribute positively to the public realm.

→ DESIGN IDEAS: Ground-level external wall design ideas that contribute positively to the public realm include high-quality, robust:

- Brick and concrete materials that create facades with depth and articulation, particularly where walls are built to street frontages
- Materials that contribute to pedestrian interest with texture, shadow and warmth
- Permeable materials and fittings that provide filtered views, shadow and detail.

→ GUIDANCE: Use weather protection at main building entries including canopies, awnings or recessed doorways.

→ GUIDANCE: Integrating signage into the façade adds interest and assists with wayfinding to each building entry.

→ GUIDANCE: Locating the accessible ramp or platform lift inside the building entry provides a better pedestrian experience.



Nightingale 1, Brunswick

The recycled brick base building has integrated signage, and the industrial steel windows and pedestrian awning provide depth and articulation and fit the urban character of the area.

Architect: Breathe Architecture. Photo: Tom Ross.



Walsh Street, South Yarra

Permeable screens to the building entry, the front fence and shutters to the upper levels provide detail, depth and filtered views.

Architect: MAArchitects and Carr Design Group with Neometro. Photo: Derek Swalwell.



Elwood House, Elwood

The building's entrance is signalled by textured, off-form concrete that contrasts with the external walls, a sculpture and integrated signage.

Architect: Woods Bagot. Landscape: Tract Consultants. Photo: Trevor Mein.

3 Design external walls, materials and details for the future practical maintenance of a building.

→ GUIDANCE: Vertical external wall designs:

- Facilitate access for maintenance to external walls, windows and roofs
- Enable the use of load-bearing durable external materials
- Minimise exposed junctions of building materials that may result in water penetration.

→ GUIDANCE: Select materials that are low maintenance and resist staining when detailed correctly. These materials include brick, glass, steel and concrete.

→ GUIDANCE: Early in the design process, think about how the building will be maintained and how access for maintenance will be provided.



35 Spring Street, Melbourne

The building's glazed façade and integrated frame give depth to the façade and enhance the expression of individual apartments and frames, shared outdoor spaces and apartment balconies and terraces. The vertical façade is also more durable.

Architect: Bates Smart. Photo: Peter Clarke.



Arlington Grove, Dulwich Hill, NSW

The building consistently uses one material — brick — which is naturally low maintenance, adds texture and complements the neighbouring housing. The deep blades provide shade and protection, and the vertical form provides for ease of maintenance.

Architect: Smart Design Studio. Image: Ross Honeysett.

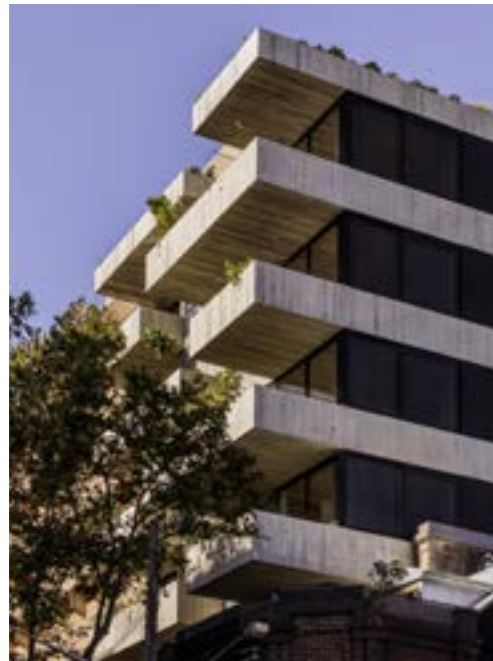

Short Lane, Surry Hills, NSW

The construction is of load-bearing concrete, a low-maintenance, durable material that adds texture. Deep balconies provide protection from the weather and access for maintenance.

Architect: Woods Bagot. Photo: Trevor Mein.

Supporting documentation

Design response

The written design response should explain the reasons for choosing the design approach to the building façade and the selection of materials for the external walls. It should:

- draw on the site’s urban or landscape context to explain how the proposed building façade design and external wall materials respond to the surrounding streetscape or landscape
- describe the qualities of the proposed external wall materials and how the materials will perform as they age over the life of the building
- provide a benchmark for considering future amendments to the building’s façade or external walls materials.

Façade drawings

Architectural drawings should support the design response, indicating the proposed materials and their locations on the building. The responsible authority may require detail drawings (at 1:50 or 1:20 scale) if the façade design and materials are not clearly conveyed or to describe the façade design and materials adjoining the public realm at street level.

Materials information



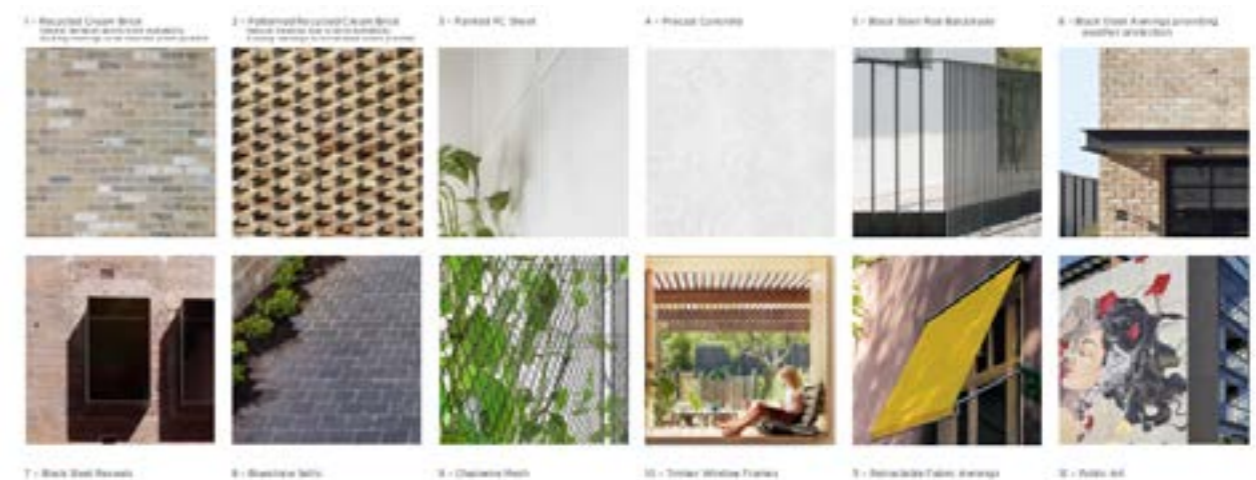





Materials should be tagged on elevations with codes, which reference images of the materials on a separate page which look like the image below.

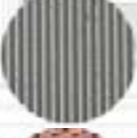

Further supporting information

The External wall materials figure below shows external walls materials that may be suitable for low-to-medium-rise apartment buildings and their aesthetic and physical qualities.

External wall materials

Material		Qualities
Brick		Durable, low maintenance, adds visual interest
Exposed aggregate concrete ¹		Durable, low maintenance, adds visual interest
Fluted concrete ¹		Durable, low maintenance
Hit-and-miss brickwork		Durable, low maintenance, adds visual interest, provides shading and ventilation
Off-form concrete ¹		Durable, low maintenance, adds visual interest
Perforated metal cladding (e.g. aluminium, Colorbond® zinc)		Sheet metal or alloy, weathers well
Standing seam metal cladding (e.g. aluminium, Colorbond®, zinc)		Sheet metal or alloy, good appearance, weathers well
Textured fibre cement façade material		Durable, low maintenance, adds visual interest

Note

¹ Adding oxide or stain to concrete can enhance its visual interest: this is illustrated in the Whitlam Place, Fitzroy picture in this chapter.

Guidance to wind impacts

Why this is important

The wind is a powerful natural force on a building and the space that surrounds it, and wind effects are influenced by the building's form, surrounds and orientation. By 'designing to the flow', architects can promote natural ventilation and mitigate detrimental wind effects at pavement level to ensure that an apartment development's communal and private outdoor open spaces are safe, comfortable places for people to enjoy and pass through.

Application

Clause 58.04-4 (wind impacts) applies to apartment developments of five or more storeys (excluding a basement) in a residential zone and all apartment developments in other zones.

Wind impacts objective (Clause 58.04-4)

To ensure the built form, design and layout of development does not generate unacceptable wind impacts within the site or on surrounding land.

Standard (D32)

Development of five or more storeys, excluding a basement should:

- not cause unsafe wind conditions specified in Table D6 in public land, publicly accessible areas on private land, private open space and communal open space; and
- achieve comfortable wind conditions specified in Table D6 in public land and publicly accessible areas on private land.

within a distance of half the greatest length of the building, or half the total height of the building measured outwards on the horizontal plane from the ground floor building façade, whichever is greater.

Trees and landscaping should not be used to mitigate wind impacts. This does not apply to sitting areas, where trees and landscaping may be used to supplement fixed wind mitigation elements.

Wind mitigation elements, such as awnings and screens should be located within the site boundary, unless consistent with the existing urban context or preferred future development of the area.

Table D6: Wind conditions

Unsafe	Comfortable
Annual maximum 3 second gust wind speed exceeding 20 metres per second with a probability of exceedance of 0.1% considering at least 16 wind directions	Hourly mean wind speed or gust equivalent mean speed (3 second gust wind speed divided by 1.85), from all wind directions combined with probability of exceedance less than 20% of the time, equal to or less than: <ul style="list-style-type: none"> • 3 metres per second for sitting areas, • 4 metres per second for standing areas, • 5 metres per second for walking areas.

Decision guidelines

Before deciding on an application, the responsible authority must consider:

- The urban context report.
- The design response.
- The safety, functionality and amenity of public, private and communal open space areas.
- Whether it has been demonstrated by a suitably qualified specialist that the development will not generate unacceptable wind impacts within the site or on surrounding land.

Design guidance

Interpreting the standard

Consider wind impacts early

The architect or building designer should collaborate with a suitably qualified wind engineer — preferably early in the design process — to identify site-specific issues and the best design solutions. This minimises the need for design changes later or poor design outcomes (such as adding screens and canopies to protect pedestrians).

Ascertain local wind conditions from prevailing winds and urban context

First, ascertain the local wind conditions including the prevailing winds and any wind protection given by existing surrounding buildings. A wind engineer can provide this advice.

Some locations (such as along coasts and in areas with tall buildings) tend to be windy, but wind impacts will be minimised if the apartment building is shielded by the surrounding built form.

Develop the basic massing of building(s) on the site

Second, develop the basic massing of building(s) on the site. Where an apartment development is five or more storeys and will be sheltered from the wind by existing surrounding buildings of similar height, a wind engineer may verify this in a wind impact assessment.

Otherwise, the building form will need to be designed to deflect wind away from outdoor areas.

The wind has three mechanical effects on buildings:

- **The downwash effect.** A typical building will deflect the prevailing wind around and over it, but also downwards, which makes streets windy. When wind hits a wall of a building, it will travel downwards at higher speeds to the street and then horizontally. Wind also accelerates around square edges, so it will accelerate around the corners of the building on the windward side.

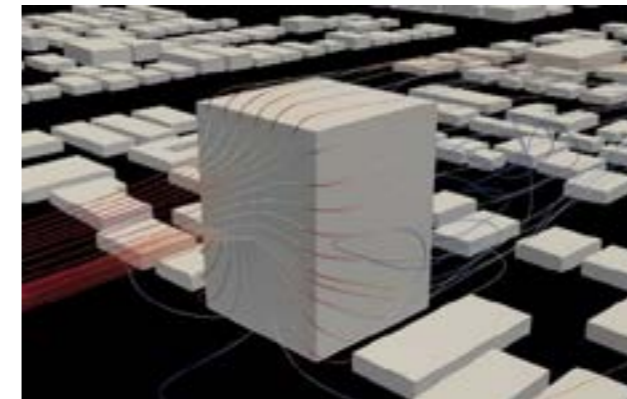

The Downwash effect

Photo: Laminar 2 Turbulent.

- **The venturi effect.** As our cities get denser, wind accelerates as it travels around and between buildings.

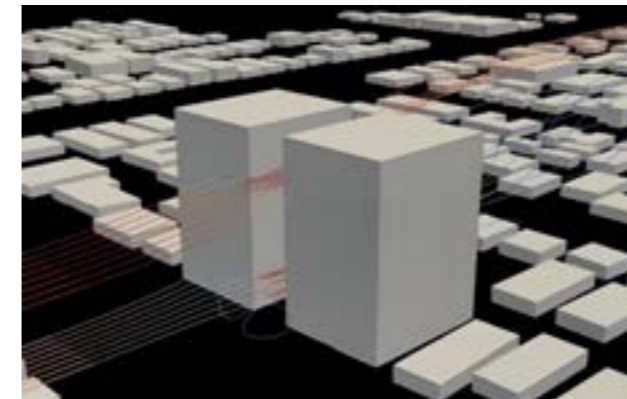

The Venturi effect

Photo: Laminar 2 Turbulent.

- **The wake effect.** As a result of the wind blowing around buildings, there is a relatively calm but gusty environment on the sheltered side of the building.

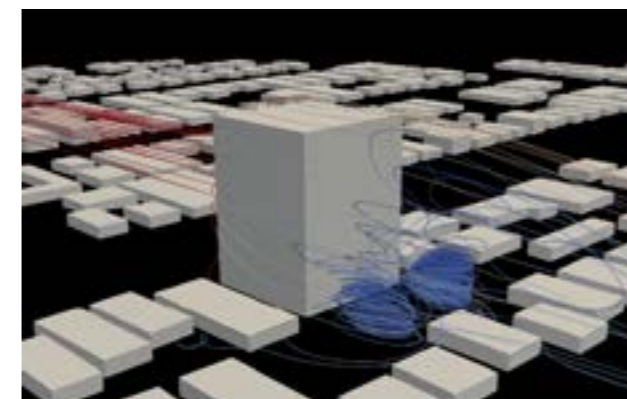

The Wake effect

Photo: Laminar 2 Turbulent.

Ascertain the assessment area

Ascertain the assessment area for the building and the scope of outdoor areas on the site and adjoining land that will be subject to the wind impact assessment.

The Assessment area figure shows the assessment area, which is typically from the edge of the proposed building outwards to a distance of the greater of:

- half its height (if the proposed building is taller than longer)
- half its length (if the proposed building is longer than taller).

Assessment area

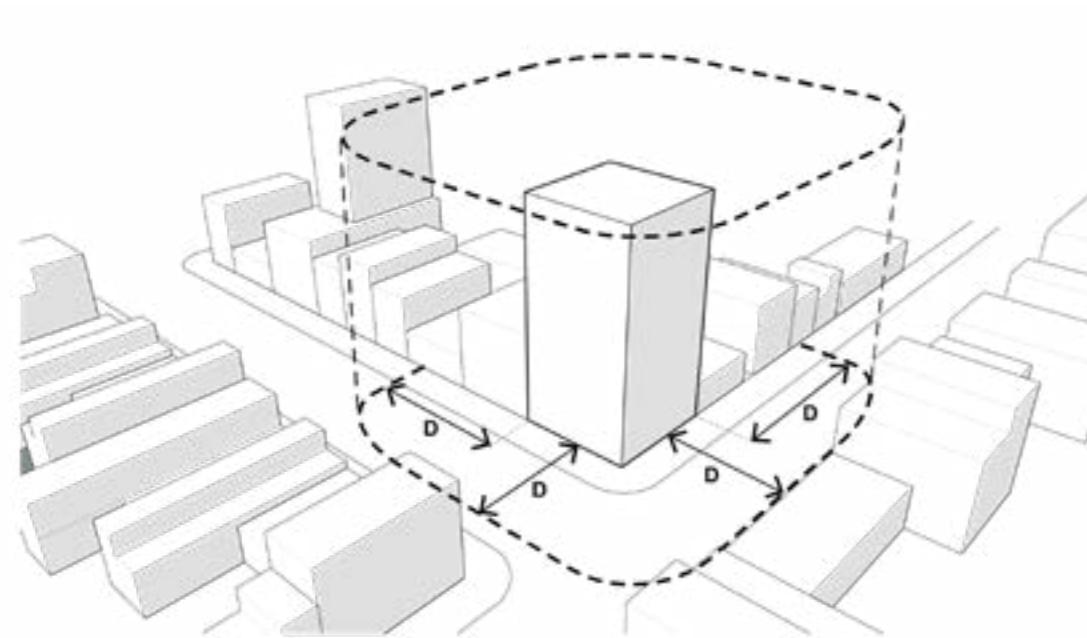

**ASSESSMENT DISTANCE D = GREATER OF:
L/2 (HALF LONGEST WIDTH OF BUILDING) OR
H/2 (HALF OVERALL HEIGHT OF BUILDING)**

Collaborate with a wind engineer to refine and finalise the design

Collaborate with a wind engineer to refine the building design to find the best design solutions to achieve safe, comfortable wind speeds in outdoor areas within the assessment area. This may be a reiterative process.

A wind engineer can calculate if a building design achieves the acceptable wind conditions in the outdoor areas within the assessment area.

Broadly, acceptable wind conditions and the places within the assessment area where they apply are:

- **safe wind conditions:** to provide safe environments, pavements, building forecourts, communal open spaces, balconies and private gardens (such as apartment gardens or neighbouring backyards) must remain safe to use during gusty winds
- **comfortable wind conditions:** to provide welcoming public spaces, pavements and building forecourts must provide comfortable wind conditions so a member of the public can walk, sit or stand (such as at an outdoor café).

As the last step, finalise and coordinate the design drawings and the wind impact assessment.

[Planning Practice Note 93 Wind Impacts in Apartment Developments](#) has more guidance about assessing wind impacts.

1 Design the basic massing of buildings on the site to avoid adverse wind impacts to the surrounding areas.

- GUIDANCE: To create pleasant outdoor areas, consider making new buildings a similar height to the surrounding buildings (and not more than twice the height of those buildings) to mitigate wind impacts at the street level. A building more than twice the height of surrounding buildings will deflect wind at higher speeds downward to the street level, particularly on the windward side of the building
- GUIDANCE: Consider wind shielding when determining the height of new buildings. Buildings that are typically no more than twice the height of their surroundings benefit from wind shielding, depending on the wind direction. The wind speed figure below illustrates how a building no more than twice the height of surrounding buildings creates low-speed winds in surrounding outdoor areas.

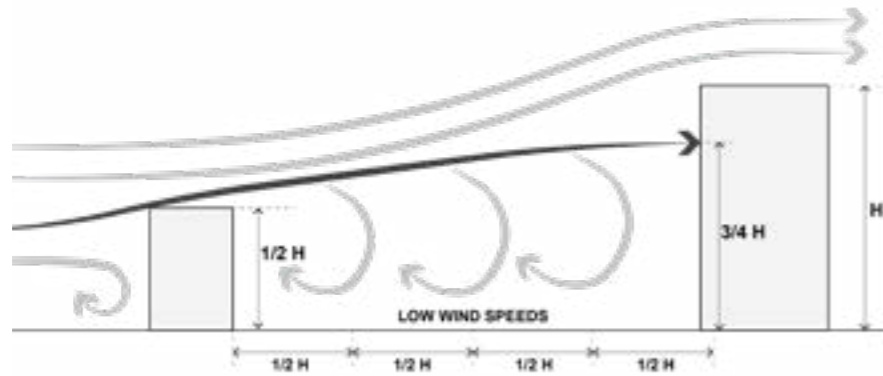

Wind Speed Figure

2 Where a building is more than twice the height of surrounding buildings, design the form of the building to deflect the wind around it.

- GUIDANCE: Design the building so the wind at higher altitudes travels smoothly around the building.
- GUIDANCE: Avoid broad building frontages that face the prevailing winds. Narrow the building form towards the prevailing wind direction to allow wind to flow around the building.
- DESIGN IDEAS: Design ideas to mitigate wind include:
 - Shaping the building so the wind travels smoothly around it rather than downwards (for example, narrow the building to the north-west and face living areas to the east).
 - Carving out the corner edges of a building so the wind travels smoothly around the corners. To do this, avoid having vertical square corners on the building in favour of broken vertical edges to the building.
 - Considering podium buildings in suburban areas: the upper storeys that are exposed to wind are set back to create a podium, which deflects wind away from the street. However, podium terraces can be windy and can be of little practical use for outdoor communal open space or private open space.



Melbourne Marriott Hotel Docklands and The Docklands Residences, Docklands

The aerodynamic building design has a narrow, north-west- pointing edge and wintergardens protected behind a curved facade.

Architect: DKO Architecture.
Architectural Visualisation: FKD Studio.



Eve Apartments, Erskineville, NSW

The built form points toward the prevailing northerlies to allow for the wind to travel smoothly around the building and for living areas to face east.

Architecture: DKO Architecture. Photo: Peter Clarke.



Queens Domain, Melbourne

The built form lacks vertical, square corners but has rounded, broken, vertical edges.

Architecture and landscaping: DKO Architecture, MDG Landscape Architects. Photo: Tom Blachford.

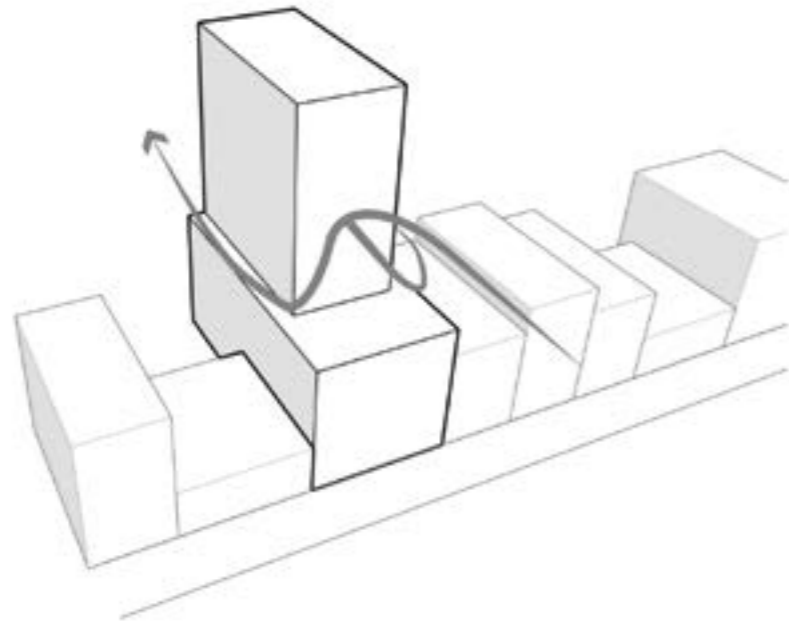

How wind flows around tower-and-podium buildings



Breese Street, Brunswick

This apartment building’s podium and the broken, vertical edges of its tower deflect the wind around the building.

Architect: DKO Architecture and Breathe Architecture. Visualisation: MR. P Studios.

3 Incorporate building elements on exteriors to avoid adverse wind impacts on the public realm and outdoor areas.

- GUIDANCE: Provide wind protection in key activity areas (such as building entrances, seating and BBQ areas).
- DESIGN IDEA: Canopies to shelter pedestrians can mitigate wind at pavement level. Uninterrupted canopies across a street frontage are most effective. Canopies can locally deflect wind flow above pedestrians in specific impact locations.
- DESIGN IDEA: Use curved or splayed building corners. Sharp corners of buildings can accentuate wind-gusting and turbulence.
- DESIGN IDEAS: Supplement windbreak features, such as screens and canopies in outdoor areas with:
 - High perimeter screening to rooftop or podium communal open spaces
 - Pergolas
 - Vertical screens
 - Trees and landscaping (such as climbing plants and planting).



Eve Apartments, Erskineville, NSW

A good example of vertical landscaping between private open space.

Architecture and landscaping: DKO Architecture, 360 Degrees Landscape Architects. Photo: Brett Boardman.



35 Spring Street, Melbourne

The uninterrupted canopy along the street frontage integrates into the façade’s frame design.

Architect: Bates Smart. Photo: Peter Clarke.

4 In larger developments, design outdoor areas and laneways to create protected spaces.

→ DESIGN IDEAS: To create pleasant outdoor areas, ideas include:

- Positioning outdoor pedestrian arcades or laneways so they point away from prevailing winds
- In larger developments, breaking up movement paths to mitigate the funnelling of wind along streets and lanes.

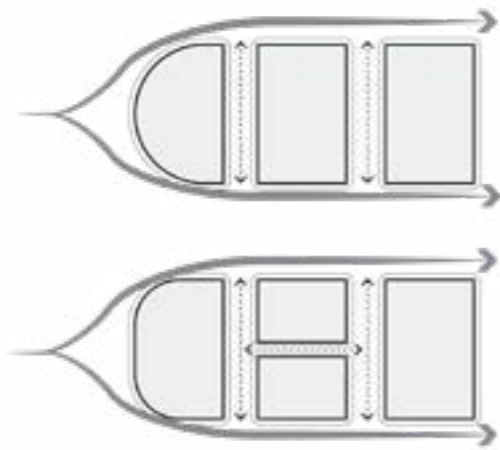

Mitigating wind funnelling

This illustration shows a large-site development utilising external pathways that point away from the prevailing wind or are in multiple directions to mitigate wind funnelling.



Assembly Apartments, North Melbourne

This large-site development utilises external pathways in multiple directions to mitigate the funnelling of wind.

Architect: Woods Bagot. Photo: Trevor Mein.



Eden Haven Sanctuary, Abbotsford

The changing level of the external pathway combined with screening mitigates the funnelling of wind.

Architect: Rothelowman. Photo: Scott Burrows Photographer.

Supporting documentation

A wind impact assessment must be provided for an apartment building of five or more stories. This is a letter or report by a qualified wind engineer:

- including advice about local wind conditions
- describing any wind-mitigation measures required to achieve the standard
- verifying that the wind conditions in the standard will be achieved in the outdoor areas
- including the calculations on which the verification is based
- for large developments, possibly recommending wind tunnel modelling.

Architectural and landscape drawings consistent with the wind-mitigation measures described in the wind impact assessment must also be provided.

For larger developments, the responsible authority may require wind tunnel modelling. This involves testing a scale model of the building in a wind tunnel.

Guidance to integration with the street

Why this is important

Active, vibrant, safe streets and neighbourhoods are created by the people who inhabit and visit their buildings, which have been thoughtfully designed to integrate with the street: to allow views to activities inside, accommodate uses that 'spill outside' and contribute to street life, and to be welcoming and visually interesting to passers-by. Such buildings contribute to pedestrians' feelings of safety and enjoyment of the public realm, attract people to visit buildings and provide a sense of address for occupiers.

Application

Clause 55.07-17 (Integration with the street) applies to apartment developments of four storeys or less (excluding a basement).

Clause 58.02-5 (Integration with the street) applies to apartment developments of five or more storeys (excluding a basement) in a residential zone and all apartment developments in other zones.

Integration with the street objective (Clause 58.02-5 or Clause 55.07-17)

To integrate the layout of development with the street.

To support development that activates street frontages.

Standard (D5 or B51)

Development should be oriented to front existing and proposed streets.

Along street frontages, development should:

- Incorporate pedestrian entries, windows, balconies or other active spaces.
- Limit blank walls.
- Limit high front fencing, unless consistent with the existing urban context.
- Provide low and visually permeable front fences, where proposed.
- Conceal car parking and internal waste collection areas from the street.

Development next to existing public open space should be designed to complement the open space and facilitate passive surveillance.

Decision guidelines

Before deciding on an application, the responsible authority must consider:

- Any relevant urban design objective, policy or statement set out in this scheme.
- The design response.

Design guidance

Interpreting the standard

What is meant by 'integration with the street'?

Integration with the street occurs when an apartment building provides active uses onto the street, public space or laneway, both at the street level and the upper levels. Integration contributes to the safety and amenity of the public realm by providing passive surveillance, visual interest and an outlook for apartment occupiers.

How the building integrates with the street will vary according to the urban context and the area. An apartment building will typically have a public-facing frontage which addresses the primary street. It may also have another one or two frontages to secondary streets (such as a local side street or laneway). An apartment building might also front a public open space.

Activating street frontages

The degree of street frontage activation can be graded from high (in activity centres) to low (in suburban streets), responding to the surrounding urban and streetscape conditions. Different activation responses will be appropriate in different contexts.

1 Activate the public realm appropriate to the urban context to provide passive surveillance and visual interest.

→ DESIGN IDEAS: To activate the public realm, ideas include:

- Providing individual pedestrian access to commercial premises from the street frontage
- Avoiding extensive use of blank walls
- Where there are blank walls, using treatments like landscaping, varied external wall materials and public artwork
- Orienting private open space and living areas toward the street frontage with a semi-permeable or low fence and landscaping to the ground-level dwellings
- Mixing uses in buildings, with retail and other commercial uses at street level and dwellings on upper floors to provide activity during the day and evening
- Providing a compatible mix of activities on the ground level (such as lobbies, cafes, restaurants and dwellings) that attracts people after business hours
- Using upper floor windows and balconies to help activate the street front.

→ GUIDANCE: Locating the main residential entry at the primary street frontage will activate the street frontage.

→ GUIDANCE: Where a building has multiple street frontages or abuts public open space, providing individual pedestrian access to ground-floor dwellings or groups of upper floor dwellings will activate and provide passive surveillance to the street.



Andara Residences, Sydney

Balconies overlook the public realm and ground-floor activation is by opening up restaurants to a terrace under a canopy and a bold pavilion structure.

Architect: FJMT Studio. Photo: John Gollings.



The Commons, Brunswick

Balconies overlook the public realm and there is ground-floor activation by providing street furniture, canopy, integrated signage, permeable facade and fire services integrated as part of the façade.

Architect: Breathe Architecture. Photo: Tom Ross.

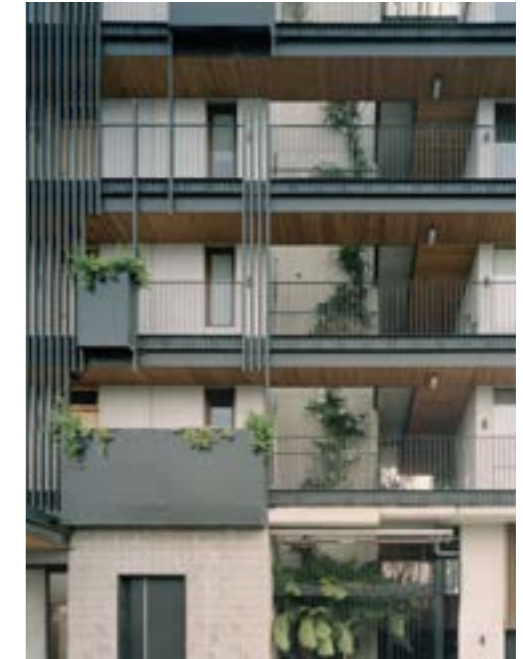

Nightingale 2, Fairfield

Walkways on upper levels provide passive surveillance of the street. The entry is legible and includes bench seating, wayfinding and signage. Services are integrated.

Architecture and landscaping: Six Degrees Architects, SBLA landscape architecture + urban design. Photo: Rory Gardiner.



One A Apartments, Erskineville, NSW

The street interface on the sloping site with elevated dwellings provides interest and passive surveillance, as well as private open space and balconies. Juliet balconies can also be used to enliven upper-storey windows.

Architects: Breakspear Architects, Kann Finch. Photo: Tom Ferguson.



Hawke + King apartments, West Melbourne

Ground-floor activation is by providing a glimpse of the central outdoor communal open space beyond the building entry, which is signified by a lantern, signage and gate. Apartment private open space, balconies and living areas provide passive surveillance of the public realm.

Architect: Six Degrees Architects. Landscaping: TNLA Landscape Architects. Photo: Binyan.

Holme Apartments, Collingwood

Ground-level activation is by visually connecting the lobby to the street. Details add visual interest and include the existing building's fabric, decorative screen, signage, entry canopy and windows to ground-level active uses.

Architect: John Wardle Architects. Photo: Michael Gazzola.

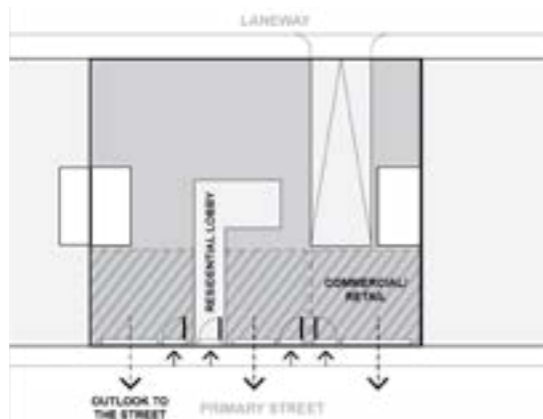

Commercial/retail premises might be positioned to the street frontage in an activity centre context

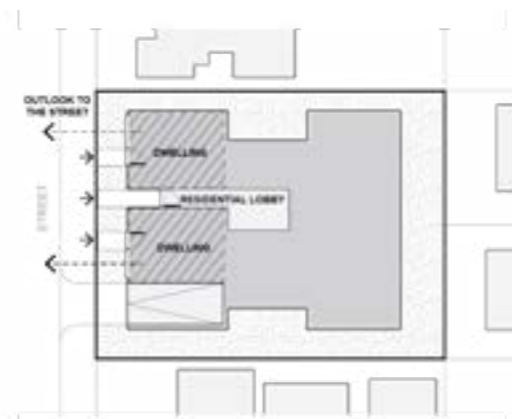

Ground-floor dwellings might be positioned toward the street frontage in a suburban context

2 Provide privacy for ground-floor dwellings and passive surveillance of the public realm appropriate to the site context.

- DESIGN IDEAS: In urban contexts, where ground-floor dwellings are located to the street edge, ideas to achieve both privacy and passive surveillance include:
 - Visually permeable operable screens or louvres
 - An elevated ground floor no more than one metre above the ground
 - In-built planters with landscaping
 - A semi-permeable or low fence to the street edge.
- DESIGN IDEAS: In suburban contexts, where ground-floor dwellings are set back from the street, ideas include a front garden which is a:
 - Private open space enclosed with fencing 1.2 metres high that is permeable
 - Communal open space to the street edge with private open space and living areas to the building edge.
- DESIGN IDEA: Where the site is sloping, step the building to follow the fall and provide an excavated or elevated ground-floor level of no more than one metre above the ground.
- DESIGN IDEA: A dwelling's private open space and living area can provide passive surveillance that can improve the amenity and vibrancy of a street.
- GUIDANCE: In suburban contexts:
 - For corner sites, provide individual entries to ground-level dwellings along secondary street frontages
 - Where front fences are greater than 1.2 metres high, make them permeable or incorporate landscaping to allow surveillance and reduce blank walls on the street.



George Corner, Fitzroy

The street-edge dwelling has a visually permeable screen door and landscaping in a planter.

Architect: MAArchitects. Photo: Derek Swalwell.



Little Oxford, Collingwood

Street-edge dwellings and terraces are elevated above the street to provide passive surveillance of the street.

Architect: Kennedy Nolan. Photo: DELWP

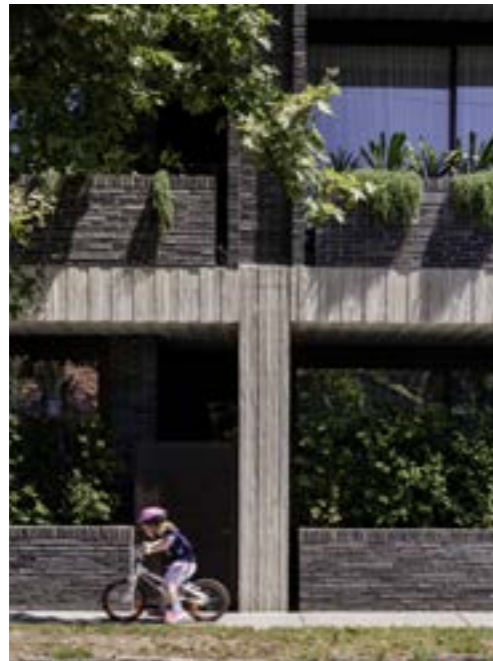

Elwood House, Elwood

Street-edge dwellings have in-built planters with landscaping.

Architect: Woods Bagot. Landscape: Tract Consultants. Photo: Trevor Mein



9 Smith Street, Fitzroy

Street-edge dwellings have a 1.2-metre high permeable fence to their front gardens that balances privacy, outlook and passive surveillance of the street.

Architect: MAArchitects. Photo: Derek Swalwell.



Ten to Twelve Lindsay Street, Brighton

The building is set back from the street. Private front gardens behind permeable front fencing allow for passive surveillance of the street.

Architect: Conrad Architects. Landscape: Jack Merlo. Illustration: MR. P Studios.



Communal open space as a front garden

This communal open space as a front garden has canopy trees as a foil to private open space for ground-floor dwellings and a permeable fence to balance privacy and passive surveillance.



President Avenue Apartments, Sutherland, NSW

Raised dwellings on a sloping site have an articulated concrete façade that protects privacy while allowing passive surveillance of the street. Dense evergreen tree planting will shield the lower courtyard dwellings.

Architect: Candalepas Associates. Photo: Brett Boardman.

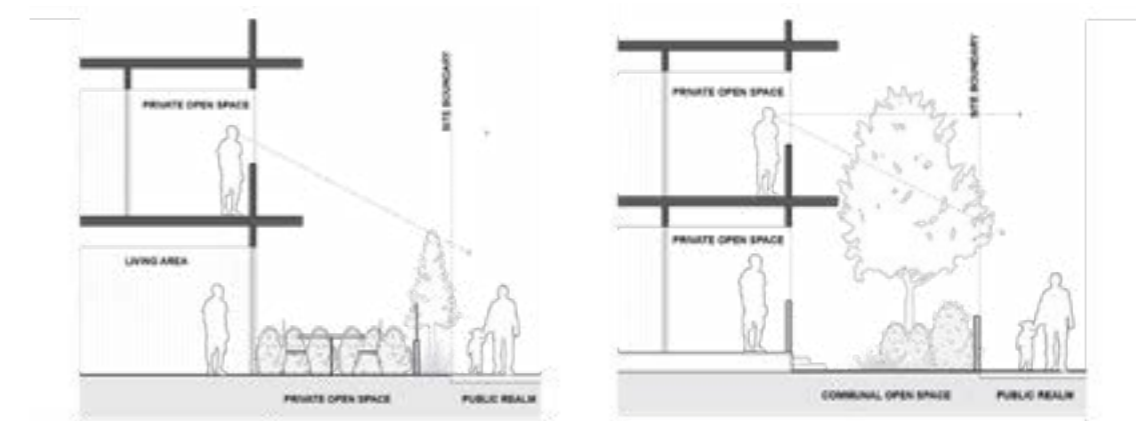

Dwellings set back from the street frontage

These set-back dwellings provide a balance between outlook and passive surveillance.

Guidance to access

Why this is important

Entering and exiting an apartment development are important moments for the people who occupy and visit it. Making arrival and departure safe, welcoming and well-facilitated experiences — as do good design for pedestrians, cyclists and drivers — contributes to the building's functionality and amenity. And as entrances and exits are inevitably on façades, they are key elements of how the building integrates with the street.

Application

Clause 55.07-6 (Access) applies to apartment developments of four storeys or less (excluding a basement).

Clause 58.03-6 (Access) applies to apartment developments of five or more storeys (excluding a basement) in a residential zone and all apartment developments in other zones.

Access objective (Clause 58.03-6 or Clause 55.07-6)

To ensure that vehicle crossovers are designed and located to provide safe access for pedestrians, cyclists and other vehicles.

To ensure that vehicle crossovers are designed and located to minimise visual impact.

Standard (D11 or B40)

Vehicle crossovers should be minimised.

Car parking entries should be consolidated, minimised in size, integrated with the façade and where practicable located at the side or rear of the building.

Pedestrian and cyclist access should be clearly delineated from vehicle access.

The location of crossovers should maximise pedestrian safety and the retention of on-street car parking spaces and street trees.

Development must provide access for service, emergency and delivery vehicles.

Decision guidelines

Before deciding on an application, the responsible authority must consider:

- The design response.
- The impact on the street.
- The impact on the safety of pedestrians or cyclists.
- The reduction of on-street car parking spaces.
- The effect on any significant vegetation on the site and road reserve.

Design guidance

Interpreting the standard

- 1 **Minimise the impact of vehicle access to the streetscape.**
 - DESIGN IDEAS: To minimise the impact of vehicle access to the building, ideas include:
 - Locating the vehicle entry/exit in the side or rear laneway
 - For corner sites, locating the vehicle entry/exit on the secondary frontage away from the corner
 - GUIDANCE: Providing vehicle access to the building at one entry/exit will minimise the impact of vehicle access on the streetscape.
 - GUIDANCE: Where crossovers are required on the primary street frontage, locating the crossover near a side boundary will minimise its impact on the street frontage.
 - GUIDANCE: Providing splayed building corners at vehicle entries will help pedestrians see oncoming vehicles.
 - GUIDANCE: Locating the vehicle entry at the lowest part of the site will minimise ramp lengths, excavation and building heights.
 - GUIDANCE: Avoid on-site drop-off facilities or car parking within street setbacks. Where these are provided, external finishes and landscaping should be consistent with the rest of the building.
 - GUIDANCE: Providing service vehicle access and dedicated parking bays concealed within basement levels enables loading/unloading and waste collection to occur away from street frontages.
 - GUIDANCE: On large development sites with multiple buildings, providing emergency vehicle access and parking within the site enables convenient access to building entries.



Little Oxford, Collingwood

Vehicle access to the building is from the side lane and is not visible from the street frontage and building entrance, which includes integrated signage, concealed services and bicycle parking.

Architect: Kennedy Nolan. Photo: DELWP.



Whitlam Place, Fitzroy

Vehicle access to the building is from the rear lane and is not visible from the primary street or public parkland.

Architect: Freadman White in collaboration with Anon Studio. Photo: Gavin Green.



Oxford and Peel, Collingwood

Vehicle access is on the secondary street frontage, with a recessive and integrated car parking entry/exit.

Architecture: Jackson Clements Burrows Architects. Photo: Peter Clarke.

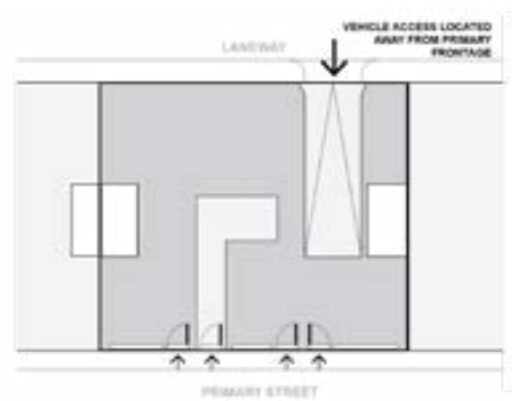

Vehicle access in an activity centre context

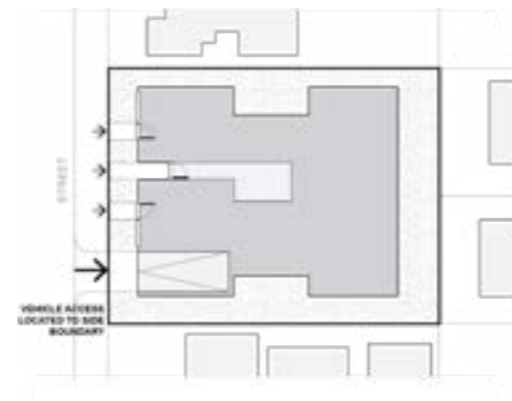

Vehicle access in a suburban context

2 Prioritise safe pedestrian and cycle access to the site.

→ DESIGN IDEAS: To prioritise pedestrian and cyclist safety, ideas include separating them from vehicles such as by:

- A separate pathway for cyclists and pedestrians leading to the building entry, separated from the driveway
- Cyclists accessing the building using the pedestrian entry on the primary street frontage.

→ DESIGN IDEAS: Where it is not possible to separate cyclists and pedestrians from vehicles, ideas include providing features between vehicle and pedestrian access paths such as:

- A change in surface level
- Varying surface treatments
- Landscaping buffers
- For internal roads, incorporating traffic calming measures including rumble strips, pinch-points or raised speed tables.

→ GUIDANCE: Providing direct access to the bike storage area from the main lobby or a separate bike entry will prioritise cyclists' safety.



Nightingale 2, Fairfield

This development has wayfinding signage for direct, separate cyclist access into the building.

Architecture and photo: Six Degrees Architects.

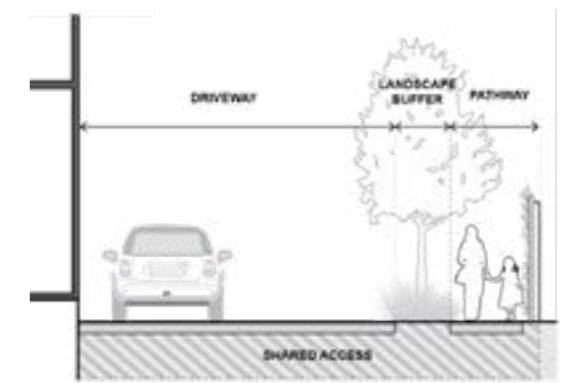
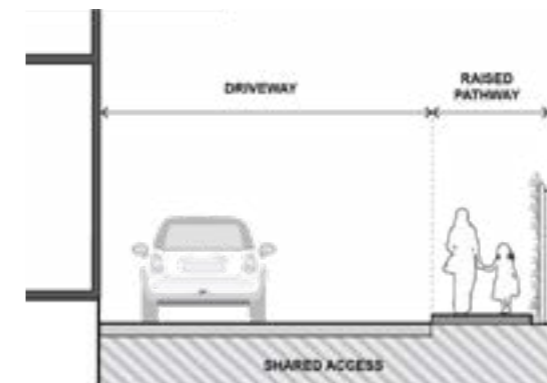

Treatments to shared pedestrian-vehicle access



Nightingale 1, Brunswick

There is direct access to the bicycle storage area from the pedestrian building entry.

Architect: Breathe Architecture. Photo: Peter Clarke.

3 Design vehicle access as a recessive and integrated component of the building facade.

→ DESIGN IDEAS: To design car parking access as a recessive and integrated component of the building, ideas include:

- Providing permeable security gates/doors at the street edge
- Recessing car park entries from the main façade alignment

→ GUIDANCE: Avoid creating entrapment spaces when recessing car park entries.

→ GUIDANCE: Finishing garage doors with materials and colours minimises their visibility from the street.

→ GUIDANCE: Providing landscaping along driveways and retaining walls can soften and screen hard surfaces.



2 St Georges Road, Fitzroy North

There is recessive, integrated vehicle access in the building's façade (on the far right side).

Architect: Fieldwork. Photo: Rory Gardiner.



122 Roseneath Street, Clifton Hill

Integrated vehicle access is set back in the front façade (on the far left side) with clear sightlines for pedestrians. The garage door adds visual interest and conceals the car park.

Architect: Fieldwork. Photo: Tatjana Plitt.



Cirqua Apartments, Ivanhoe East

Integrated vehicle access is set back in the front façade (on the far left-hand side) with clear sightlines for pedestrians. The garage door conceals the car park.

Architect: BKK Architects. Photo: Peter Bennetts.

Guidance to site services

Why this is important

The provision of site services, many of which have regulatory requirements, is an important aspect of the building's amenity and functionality, how it interacts with the world around it and the flow of people, goods and services in and out of it. Creative design can maximise the accessibility and ease and economy of installation and maintenance of site services and their visual impact by careful integration into the building design and landscape.

Application

Clause 55.07-18 (Site services) applies to apartment developments of four storeys or less (excluding a basement).

Clause 58.06-2 (Site services) applies to apartment developments of five or more storeys (excluding a basement) in a residential zone and all apartment developments in other zones.

Site services objective (Clause 58.06-2 or Clause 55.07-18)

To ensure that site services are accessible and can be easily installed and maintained.

To ensure that site services and facilities are visually integrated into the building design or landscape.

Standard (D22 or B52)

Development should provide adequate space (including easements where required) for site services to be installed and maintained efficiently and economically.

Meters and utility services should be designed as an integrated component of the building or landscape.

Mailboxes and other site facilities should be adequate in size, durable, weather-protected, located for convenient access and integrated into the overall design of the development.

Decision guidelines

Before deciding on an application, the responsible authority must consider:

- Any relevant urban design objective, policy or statement set out in this scheme.
- The design response.

Design guidance

Interpreting the standard

Consider site services early

To support the creation of more street frontage activation, consider service locations early in the design process.

Locate and design services to meet the requirements of service authorities and utilities. Engage with them early — before submitting the planning permit application — to determine the type, extent and location of services infrastructure and meters they require in the apartment building. Early engagement may allow for more flexibility in the design and placement of services.

Integrating services

Options for integrating site services should be based on the following approaches:

- Making the site services an incorporated design element within the appearance of the building
- Moving the site services deeper into the building, away from busy pedestrian-use areas
- Minimising the visual impact of remaining services by screening and disguising them.

1 Locate services away from the primary street frontage.

→ GUIDANCE: If services cannot be made an attractive component of the building design, locating them away from pedestrian areas, subject to service authorities' requirements, allows more space for active uses in the street frontage. Consider locating services:

- At the rear of the building, facing a laneway
- Away from pedestrian entrances on primary street frontages
- Running alongside vehicle entries.

→ GUIDANCE: Where services are located in internal common areas, integrate the services into the interior design.

→ GUIDANCE: Consolidating access to services with car parking including waste collection and loading/unloading areas minimises their impact on the streetscape.



Upper House Apartments, Melbourne

These apartments have an activated street frontage with services located away from the primary street.

Architect: Jackson Clements Burrows.
Photo: John Gollings.



Oxford and Peel, Collingwood

Services are minimised on the primary and secondary street frontages. Where they do occur on the secondary street frontage, they are concealed behind dark-coloured panels.

Architecture: Jackson Clements Burrows Architects. Photo: Peter Clarke.

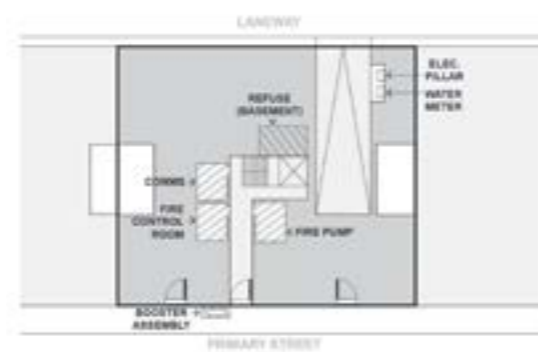
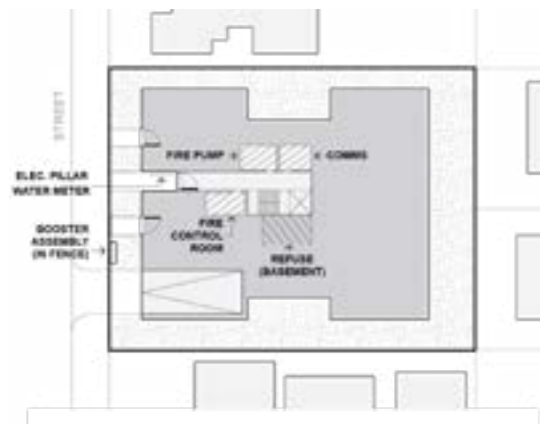

Service locations

These drawings show ideas for locating services away from the primary street frontage, having regard to the site context.

2 Minimise the visual impact of services located in the street frontage areas.

- GUIDANCE: Consider with the service authority whether meters can be distributed rather than be in one location.
- GUIDANCE: Where the service authority requires services or meters to be in an active space (such as a street frontage), minimise their visual impact and integrate the services and signage into the design of the building.
- DESIGN IDEAS: To integrate the services into the design of the building, ideas include:
 - Exposing services such as hydrants and painting pipes to complement the façade
 - Integrating service cupboards into the façade so they are not noticeable
 - Using half-height service cupboards
 - Using a freestanding unit of a colour that complements the landscaping
 - Concealing services behind permeable decorative screening or fencing in complementary matching materials.
- GUIDANCE: Ensure peoples' safety by gating service alcoves or entrapment spaces to street and/or laneway interfaces.



Whitlam Place, Fitzroy

A small number of meters and fire services are disguised by landscaping in a narrow planter.

Architect: Freadman White in collaboration with Anon Studio. Photo: Gavin Green.



Napier Street for Milieu, Fitzroy

Services are concealed in part-height cupboards with landscaping in planters above to provide privacy and soften the facade.

Architect: Freadman White. Photo: Gavin Green.



Little Oxford, Collingwood

Services are concealed in louvre grille cupboards in a contrasting and recessive colour to the façade.

Architect: Kennedy Nolan.

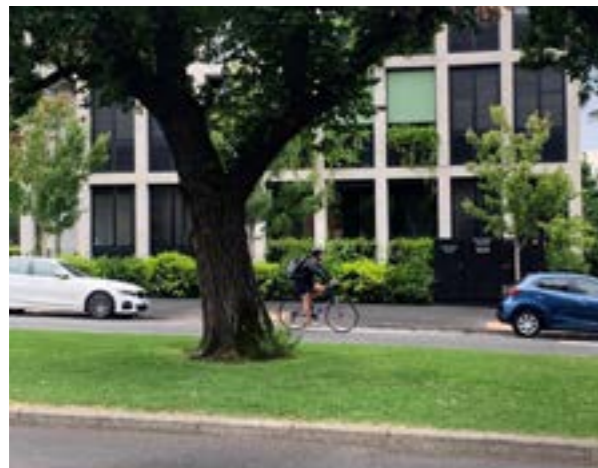

George + Powlett, East Melbourne

Services are housed in a freestanding unit in a complementary colour to the fencing and facade.

Architect: Powell + Glenn. Photo: DELWP

3 Locate substations and switch rooms to address service authorities' requirements.

- DESIGN IDEA: To locate electrical services away from the primary street, ideas include locating them in a utility room with direct access off a secondary street or rear laneway.
- DESIGN IDEAS: In special circumstances and before making the planning application, ideas include working with the service provider to locate the electrical services in the:
 - Uppermost basement level (where they are not impacted by flooding) where access is provided from the car park
 - Podium level above the ground floor.
- GUIDANCE: Placement and layout should ensure:
 - 24-hour access
 - Compliance with the requirements of the relevant service authorities.

4 Locate fire boosters to address service authorities' requirements.

- DESIGN IDEAS: To locate fire booster services, consider locating them on the ground floor abutting the primary street frontage:
 - integrated into service cupboards so they are not noticeable, or
 - if services are discreet, paint the pipes to complement the façade
- GUIDANCE: Ensuring fire boosters and other fire services do not intrude into active spaces and incorporating them into the building's look and appearance will improve the presentation of the building.
- GUIDANCE: Placement should ensure:
 - 24-hour access for firefighters and fire trucks
 - Services are in sight of the main entrance of the building, either 10 metres away from the building or protected from any fire in the building
 - Compliance with location requirements of the relevant service authorities.

5 Locate gas and water meters to address service authorities' requirements.

- DESIGN IDEAS: To locate gas and water meters, consider locating them in semi-permeable enclosures:
 - Abutting the primary or secondary street where distances allow
 - Perpendicular to the street frontage to minimise their visual impact
 - In outdoor common areas, where access and distances allow.
- NOTE: Gas meters must be located within 1.5 metres of any roadway and close to the building entry if possible. Water meters must be located within 2 metres of the front boundary. Where this cannot be achieved, water meters can be located within the uppermost level of the basement car park and adjacent to the front boundary.
- GUIDANCE: Placement should ensure:
 - 24-hour access
 - Ease of access for metering, replacement and repair
 - Compliance with the location requirements of the relevant service authorities.



109 Dight Street, Collingwood

Services are concealed in ventilated grille cupboards in a complementary colour to the façade.

Architect: Fieldwork. Photo: Dan Hocking.

6 Nominate a suitable location and design treatment for mechanical services.

- GUIDANCE: Concealing mechanical services with other 'active' building uses will mean they are less visible on the building facade.
- GUIDANCE: Orienting hot exhaust outlets away from active or residential use areas and trees will improve amenity for pedestrians and residents.
- GUIDANCE: Screening and noise-isolating mechanical equipment from active spaces will minimise noise impacts on these areas.
- GUIDANCE: Use air conditioning systems that avoid individual apartment condenser units or conceal them from view in the public realm.

7 Locate back-of-house facilities away from building entries.

- DESIGN IDEAS: To conceal back-of-house facilities including waste and recycling services, design ideas include:
 - Where the facilities are located off a laneway, providing natural ventilation and daylight through a permeable façade (such as 'hit-and-miss' brickwork or perforated screening)
 - Locating the facilities in an area that is visually obscured but easily accessible for residents
 - Concealing the facilities with other more active spaces (such as commercial premises, common areas or communal open space).



Waste room location

The waste room is located on the ground floor and is accessed from a laneway.

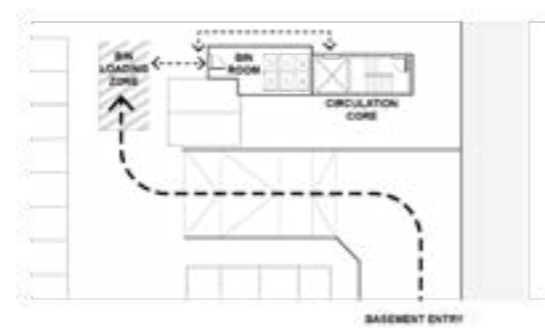

Waste room location

The waste room is located in the basement, and it is accessed from the main vehicle entry to a dedicated loading bay.

8 Locate entry intercoms and mailboxes close to building entries.

- DESIGN IDEA: Locate the mailboxes in a discreet form to provide a sense of address and place at the building entry.
- GUIDANCE: Locate apartment intercoms, mailboxes and parcel post facilities close to the building entry/lobby where they are visible from the street and convenient and safe to access for residents and service providers.
- GUIDANCE: Provide a weather-protected and well-lit mailbox area to create opportunities for informal surveillance from apartments or ground-floor uses.



Napier Street for Milieu, Fitzroy

Mailboxes are located at the building entry, and there is integrated building signage.

Architect: Freadman White. Photo: Gavin Green.



Housing Choices Australia

Mailboxes have a form and materials that respond to the neighbourhood.

Architect: Kennedy Nolan. Photo: Derek Swalwell.

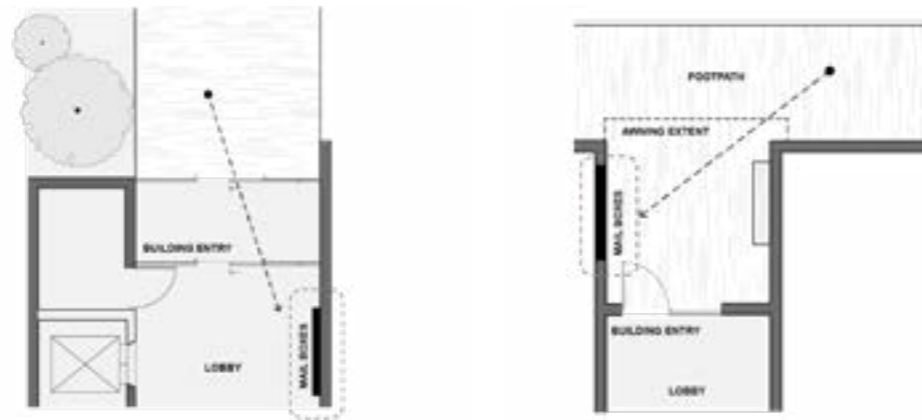

Mailbox locations

These are ideas for mailbox locations internal and external to a building.

Supporting documentation

Provide architectural drawings that are consistent with service authorities' requirements for services infrastructure and meters. Indicate façade and/or fencing treatments or the services visible in the public realm.

Guidance to building entry and circulation

Why this is important

Apartment entries add to the quality and character of the street and pedestrian experience. Well-designed apartment entries and circulation spaces create a sense of identity, encourage social interaction and support safe and convenient access for occupants and visitors to apartment developments.

Application

Clause 55.07-8 (Building entry and circulation) applies to apartment developments of four storeys or less (excluding a basement).

Clause 58.05-2 (Building entry and circulation) applies to apartment developments of five or more storeys (excluding a basement) in a residential zone and all apartment developments in other zones.

Building entry and circulation objectives (Clause 58.05-2 or Clause 55.07-8)

To provide each dwelling and building with its own sense of identity.

To ensure the internal layout of buildings provide for the safe, functional and efficient movement of residents.

To ensure internal communal areas provide adequate access to daylight and natural ventilation.

Standard (D18 or B42)

Entries to dwellings and buildings should:

- Be visible and easily identifiable.
- Provide shelter, a sense of personal address and a transitional space around the entry.

The layout and design of buildings should:

- Clearly distinguish entrances to residential and non-residential areas.
- Provide windows to building entrances and lift areas.
- Provide visible, safe and attractive stairs from the entry level to encourage use by residents.
- Provide common areas and corridors that:
 - Include at least one source of natural light and natural ventilation.
 - Avoid obstruction from building services.
 - Maintain clear sight lines.

Decision guidelines

Before deciding on an application, the responsible authority must consider:

- The design response.
- The useability and amenity of internal communal areas based on daylight access and the natural ventilation it will receive.

- 1 **Locate the main pedestrian entry to provide a sense of address by being clearly visible and accessible from the street.**
 - GUIDANCE: Building entrances help visitors orient themselves. Entries and foyers should be comfortable, sheltered, safe, convenient and visible during the day and night.
 - GUIDANCE: Emphasise residential entry lobbies with prominent design features, signage or landscape treatments
 - GUIDANCE: Provide a sense of identity to individual dwellings with an internal entry that can be easily recognised.

- 2 **Provide clear sightlines from the foyer to the street so people can see both in and out when entering or leaving the building.**

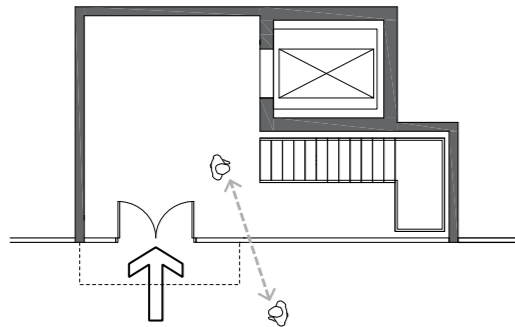

Clear sightlines to entry lobby.

- 3 **Where ground floor dwellings face the street, individual entrances can assist in promoting a sense of personal address and activate the street.**

- GUIDANCE: Elevating dwelling floors and balcony spaces slightly above the street level provides both a sense of privacy and better sightlines to streets and public spaces.
- GUIDANCE: Where ground level units are raised above street level, achieve level access via the main apartment entry door off the circulation corridor.

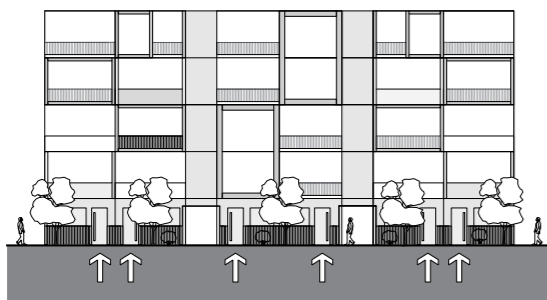

Section diagram. Ground floor dwellings with individual entries.

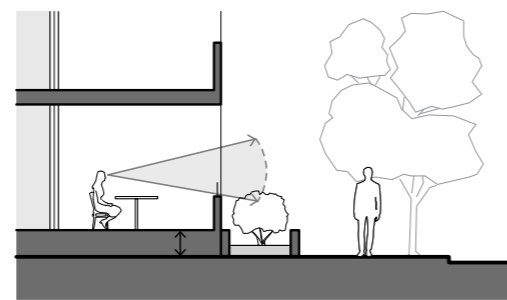

Section diagram. Elevated dwelling above the street level

- 4 **Separate the pedestrian and vehicle entries to the buildings.**

- GUIDANCE: Separating vehicle entries from pedestrian entries enhances pedestrian safety.
- GUIDANCE: Vehicle entries that are designed to be less prominent or recessive improve the streetscape.

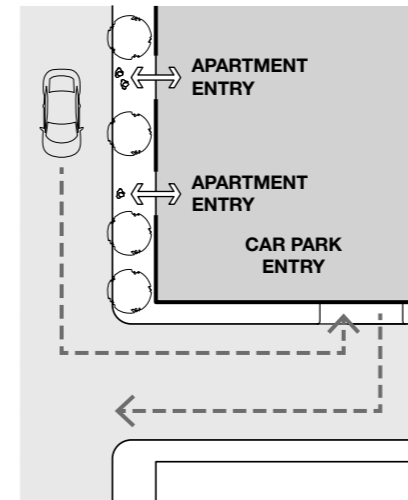

Plan diagram. Separate pedestrian and vehicle entry.

- 5 **Provide shelter and waiting space on the street at pedestrian entries to buildings.**

- GUIDANCE: Design sheltered areas outside the secure entry areas in higher density residential buildings with canopies or building overhangs.

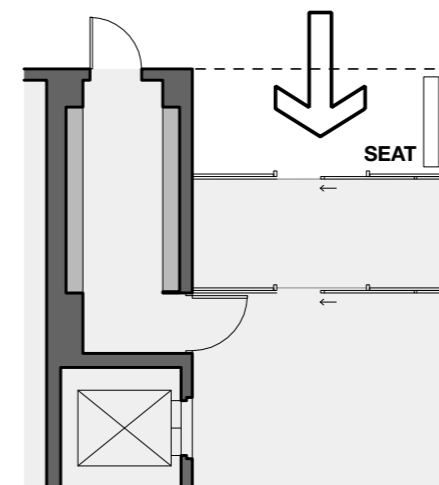

Plan diagram. Shelter and waiting space outside a lobby.

- 6 Provide mail boxes and parcel post facilities close to the building entries in a well-lit and weather protected area, with potential for informal surveillance.

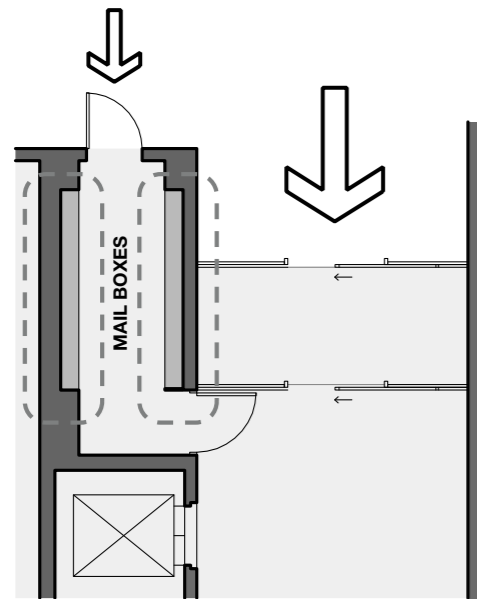

Plan diagram. A separate mailbox room with glass doors.

- 7 Locate and arrange utility service installations to minimise their impact on the building's active street frontage.

- 8 Provide appropriate access between street ground level and the entry lobby floor level for safe, functional and efficient movement.

→ GUIDANCE: Where possible, avoid steps and long ramps up to the building foyer.

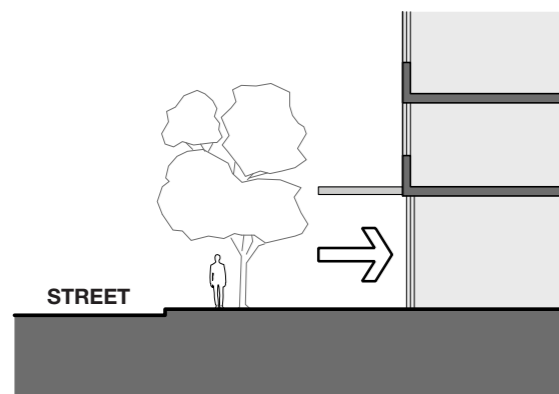

Section diagram. Convenient access to an entry lobby.

- 9 Design windows and openings in corridors to respond to the site context.

→ GUIDANCE: Design the type, placement and size of windows to respond to access to sunlight and daylight, surrounding buildings, view opportunities and outlook, informal surveillance to public and communal areas, natural and cross ventilation and any adjacent noise sources.

Supporting documentation

Nominate the source of natural light and ventilation into common areas and circulation on application plans.

Section 2 - Building Performance

Guidance to noise impacts

Why this is important

Reducing internal and external noise impacts is important to occupant wellbeing and amenity. Apartments located in urban environments near industrial areas, major roads and railway lines are subject to significant noise impacts requiring careful design responses.

Application

Clause 55.07-6 (Noise impacts) applies to apartment developments of four storeys or less (excluding a basement).

Clause 58.04-3 (Noise impacts) applies to apartment developments of five or more storeys (excluding a basement) in a residential zone and all apartment developments in other zones.

Noise impacts objectives (Clause 58.04-3 or Clause 55.07-6)

To contain noise sources in developments that may affect existing dwellings.

To protect residents from external and internal noise sources.

Standard (D16 and B40)

Noise sources, such as mechanical plants should not be located near bedrooms of immediately adjacent existing dwellings.

The layout of new dwellings and buildings should minimise noise transmission within the site.

Noise sensitive rooms (such as living areas and bedrooms) should be located to avoid noise impacts from mechanical plants, lifts, building services, non-residential uses, car parking, communal areas and other dwellings.

New dwellings should be designed and constructed to include acoustic attenuation measures to reduce noise levels from off-site noise sources.

Buildings within a noise influence area specified in Table D3 and B6 should be designed and constructed to achieve the following noise levels:

- Not greater than 35dB(A) for bedrooms, assessed as an LAeq,8h from 10pm to 6am.
- Not greater than 40dB(A) for living areas, assessed LAeq,16h from 6am to 10pm.

Buildings, or part of a building screened from a noise source by an existing solid structure, or the natural topography of the land, do not need to meet the specified noise level requirements.

Noise levels should be assessed in unfurnished rooms with a finished floor and the windows closed.

Table D3 and B6 Noise influence area

Noise source	Noise influence area
Zone interface	
Industry	300 metres from the Industrial 1, 2 and 3 zone boundary
Roads	
Freeways, tollways and other roads carrying 40,000 Annual Average Daily Traffic Volume	300 metres from the nearest trafficable lane
Railways	
Railway servicing passengers in Victoria	80 metres from the centre of the nearest track
Railway servicing freight outside Metropolitan Victoria	80 metres from the centre of the nearest track
Railway servicing freight in Metropolitan Melbourne	135 metres from the centre of the nearest track

Note: The noise influence area should be measured from the closest part of the building to the noise source.

Decision guidelines

Before deciding on an application, the responsible authority must consider:

- The design response.
- Whether it can be demonstrated that the design treatment incorporated into the development meets the specified noise levels or an acoustic report by a suitably qualified consultant submitted with the application.
- Whether the impact of potential noise sources within a development have been mitigated through design, location and siting.
- Whether the layout of rooms within a dwelling mitigates noise transfer within and between dwellings.
- Whether an alternative design meets the relevant objectives having regard to the amenity of the dwelling and the site context.

Internal noise sources

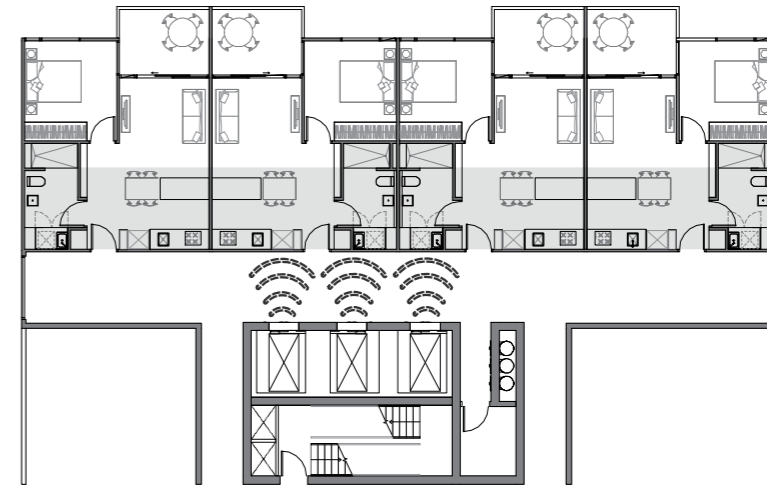

External noise sources

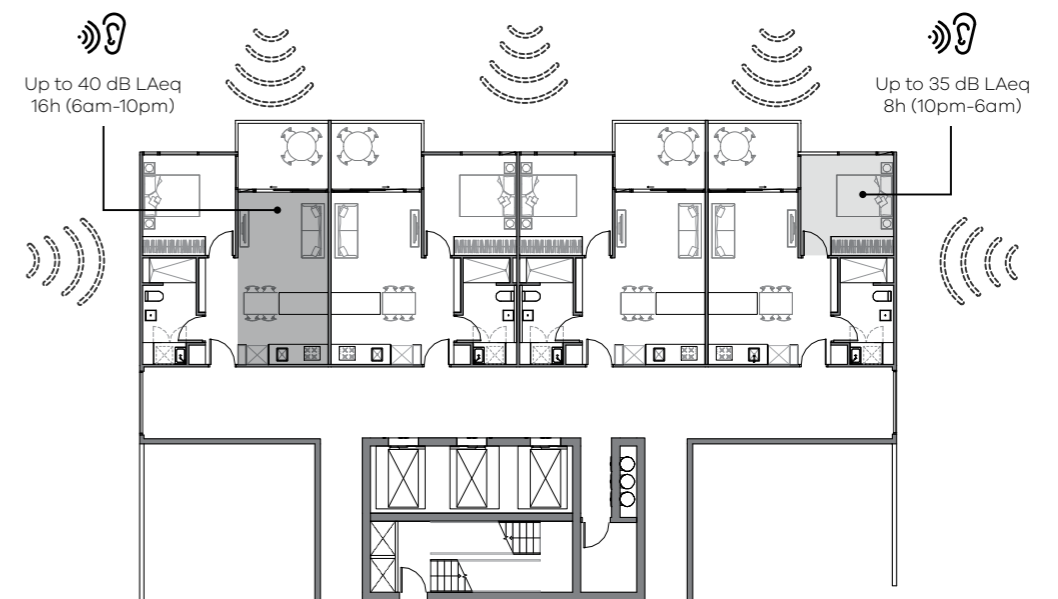

Design guidance

Interpreting the standard

An apartment development located within a noise influence area specified in Table D3 and B6 of the Standard is required to meet the specified noise levels by undertaking an assessment of the impact of external noise through either an acoustic report prepared by a suitably qualified consultant or by applying an appropriate design treatment. In some instances, an acoustic report is not required if standard design treatment for noise is used.

An acoustic report is a detailed acoustic assessment incorporating external noise exposure measurements or modelling of the proposed building design to demonstrate suitable design responses can achieve the standard.

The acoustic report must be prepared by an experienced, professional acoustic engineering consultant who should either be a member of, or have the qualifications to become a member of the Australian Acoustic Society (AAS) or the Association of Australian Acoustical Consultants (AAAC).

A standard design treatment for noise is a prescribed building construction method based on the known performance of the construction materials used including documentation, plans and product certification specifying the level of sound attenuation performance of the materials used for the relevant level of noise exposure.

When a standard design treatment for noise is applied the selection of materials must be supported by evidence of the acoustic performance of the material. A product performance specification certificate from a National Association of Testing Authorities (NATA) accredited laboratory (or international equivalent) is considered sufficient evidence.

Where a standard design treatment for noise is not available a detailed acoustic assessment will be required to demonstrate compliance with the noise standard.

Further information about an acoustic report or applying a standard design treatment for noise to meet the standard is provided in *Planning Practice Note 83: Assessing external noise impacts for apartments*.

Which approach is applicable within a Noise Influence Area?

- **Industry Noise Influence Area** - an acoustic report is required to meet the standard. There is no standard design treatment available to meet the standard.
- **Roads Noise Influence Area** - an acoustic report or a standard design treatment for noise can be used depending upon the traffic volume, speed limit and distance of road kerb.
- **Railways Noise Influence Area** - an acoustic report or a standard design treatment for noise can be used to meet the standard depending upon the type of railway line and the distance from the railway line.

Note: Refer to Planning Practice Note 83: Assessing external noise impacts for apartments to determine what standard design treatments are acceptable within a Railways or Roads Noise Influence Area.

1 If the development is not within a Noise Influence Area

- GUIDANCE: Use building siting, layout and design of dwellings to reduce the impact of external noise sources. Design techniques to mitigate noise include:
- Locating windows of habitable rooms away from noise sources or limiting the extent of openings facing the noise source.
 - Physically separating residential uses from a noise source by additional setbacks or the use of a podium.
 - Providing acoustic glazing, or enclosed balconies (winter gardens).
 - Solid balustrades incorporated into balconies to act as a shield to the noise source below.
 - Providing acoustic seals to openings.
 - Using materials with mass and/or sound absorption properties.

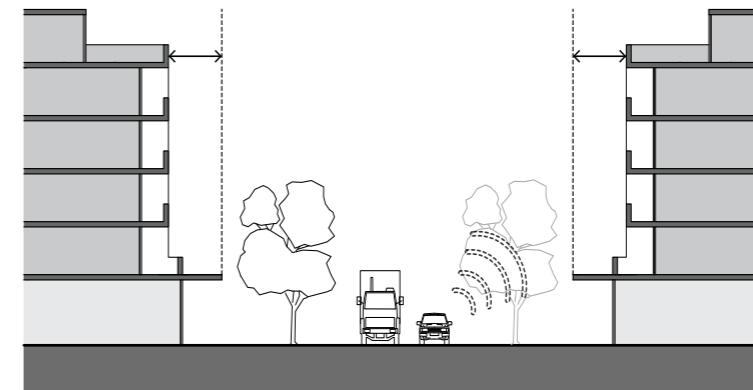

Section diagram. Podiums and barriers oriented and sized to screen noise.

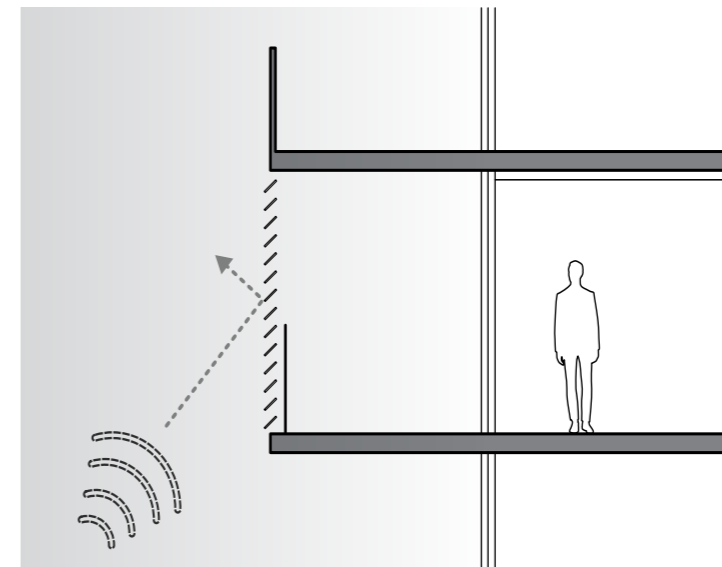

Section diagram. Wintergardens may screen noise.

2 If the development is within a Noise Influence Area

- GUIDANCE: Measure distances from the designated noise source specified in Table D3 or B6 to the nearest point of the building's external facade. Oblique line-of-sight exposure applies even if exposure is obscured directly in front of the dwelling.
- GUIDANCE: Identify portions of the external facade that are exposed to the designated noise source. Portions of the external facade obscured by a solid, permanent structure such as a noise barrier, an earth mound, an existing building or the natural topography of the land may not need to be assessed.
- GUIDANCE: While low rise buildings may benefit from shielding provided by topography, barriers or other buildings, high rise buildings usually receive less shielding and noise mitigation needs to be considered at the outset in the layout and building design.
- GUIDANCE: Demonstrate the adequacy of any 'line of sight' shielding from a new or pre-existing noise barrier wall. Refer to Planning Practice Note 83: Assessing external noise impacts for apartments for further technical guidance on this matter.

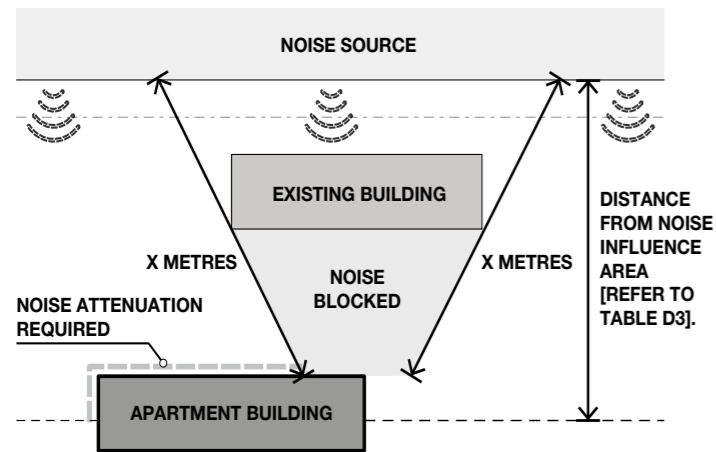

X METRES: [REFER TO TABLE D3].

Plan diagram. Determining Noise Influence Area.

3 Ventilation

- GUIDANCE: In particularly high noise locations a separate means of ventilation beyond operable windows should be considered because occupants are likely to keep windows closed and so may suffer from poor indoor air quality. Design responses can include locations ventilation openings on a quieter facade, use of borrowed ventilation, attenuated air relief openings or mechanical ventilation.

Mechanical ventilation can take many forms from wall mounted fan assisted acoustic units to central ventilation systems, but attenuated relief openings should be appropriately rated to achieve suitable sound insulation.

4 Meet the noise requirements through an acoustic report or a standard design treatment.

- GUIDANCE: Provide an acoustic report prepared by a suitably qualified acoustic consultant to demonstrate that the specified noise levels are achieved.
- GUIDANCE: Where an acoustic report is provided, the report should ensure noise modelling of the proposed building design demonstrates suitable design responses can be achieved.
- For road traffic noise, the assessment should include a minimum of three days during which the noise measurements have not been adversely affected by meteorological conditions.
- For rail noise, the assessment should include a minimum of 20 train pass-by events over a 24-hour peak day of the week period. For train lines carrying freight, the freight timetable should be consulted to ensure measurements include peak events.
- For industrial areas, where noise can be highly inconsistent, the assessment should include seven days of continuous 24 hour measurement.
- When preparing the report, noise attenuation should be applied for the whole room where the living room or bedroom is partially within the noise influence area. Bedrooms should include all ensuites and walk-in robes that do not have a permanent door separating them from the bedroom. Living areas should include all kitchen or study areas that are included within the room in open plan designs.
- GUIDANCE: Where a standard design treatment is applied the construction material should be appropriate to the external noise exposure category. Refer to Planning Practice Note 83: Assessing external noise impacts for apartments for guidance on the acoustic performance of the construction material.
- GUIDANCE: Where a standard design treatment is applied documentation to verify use of appropriate construction materials is required.

Supporting information

- Provide an acoustic report from a suitably qualified acoustic consultant including validated design and construction responses to demonstrate compliance (modelled for exposed unfurnished units with a finished floor consistent with submitted design).
- Where a standard design treatment has been adopted, provide documentation to verify appropriate materials and construction responses have been applied.
- Plans should show the distances from any designated noise sources in Table D3 and B6 Noise influence area, including details of any permanent structure that obscures (or partially obscures) the proposed building, and natural ground levels where topography of the land attenuates noise sources.

Guidance to energy efficiency

Why this is important

Apartments that are energy efficient through passive design provide good thermal comfort and daylight access and reduce energy costs. With the ongoing effects of climate change ensuring the thermal performance of apartments over summer will become increasingly important. Reducing energy costs is important for housing affordability and reducing the effects of fossil fuel consumption.

Application

Clause 55.07-1 (Energy efficiency) applies to apartment developments of four storeys or less (excluding a basement).

Clause 58.03-1 (Energy efficiency) applies to apartment developments of five or more storeys (excluding a basement) in a residential zone and all apartment developments in other zones.

Energy efficiency objectives (Clause 58.03-1 or Clause 55.07-1)

To achieve and protect energy efficient dwellings and buildings.

To ensure the orientation and layout of development reduce fossil fuel energy use and make appropriate use of daylight and solar energy.

To ensure dwellings achieve adequate thermal efficiency.

Standard (D6 or B35)

Buildings should be:

- Oriented to make appropriate use of solar energy.
- Sited and designed to ensure that the energy efficiency of existing dwellings on adjoining lots is not unreasonably reduced.

Living areas and private open space should be located on the north side of the development, if practicable.

Developments should be designed so that solar access to north-facing windows is optimised.

Dwellings located in a climate zone identified in Table D1 should not exceed the maximum NatHERS annual cooling load in the following table.

Table D1 Cooling load

NatHERS climate zone	NatHERS maximum cooling load MJ/M ² per annum
Climate zone 21 Melbourne	30
Climate zone 22 East Sale	22
Climate zone 27 Mildura	69
Climate zone 60 Tullamarine	22
Climate zone 62 Moorabbin	21
Climate zone 63 Warrnambool	21
Climate zone 64 Cape Otway	19
Climate zone 66 Ballarat	23

Note: Refer to NatHERS zone map, Nationwide House Energy Rating Scheme (Commonwealth Department of Environment and Energy).

Design guidance

Interpreting the standard

The cooling loads in Table D1 complement the energy efficiency requirements in the National Construction Code (NCC). Adoption of the cooling load cap for each apartment in a development is in addition to NCC requirements which are based on a 6-star average across an apartment development and 5-star minimum for an individual apartment.

Applying a cooling cap will improve the energy efficiency and thermal comfort of the poorer performing apartments of an apartment building compared to compliance with the NCC standard alone.

The different cooling loads reflect the varied climatic contexts across Victoria. The relevant NatHERS climate zone maps can be determined from: http://www.nathers.gov.au/sites/all/themes/custom/nathers_2016/climate-map/index.html

Energy efficiency in construction is complex and use of current best practice design and energy assessment reporting tools are normally required to demonstrate that the objectives of this Standard are met

The cooling load measure is built into the existing star rating tool (NatHERS) and compliance is demonstrated with the standard NatHERS certificate.

1 Plan for energy efficiency of buildings and involve a specialist ESD consultant early in the design process to make energy efficient design integral to the building form and layout.

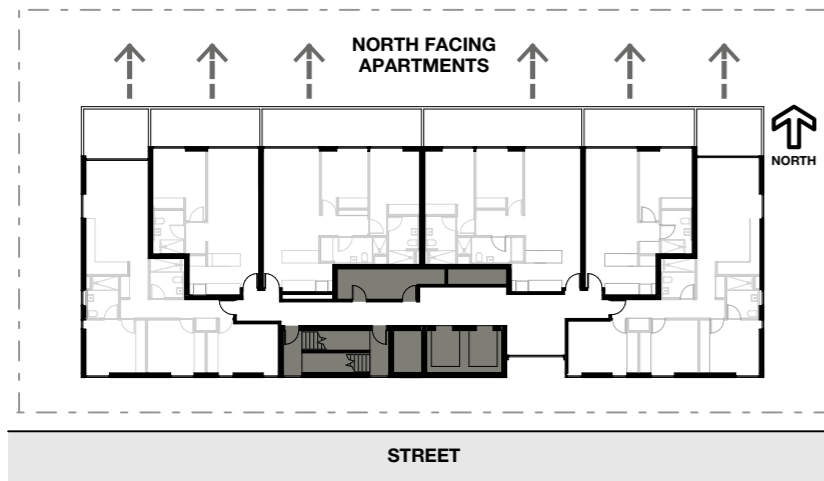

Plan diagram: Example internal layouts with good solar access.

- GUIDANCE: Configure internal apartment layouts to optimise solar access opportunities.
- GUIDANCE: Passive design principles such as correct solar orientation should be considered part of the urban context report and design response.
- GUIDANCE: Building orientation, and layout should balance addressing the street with achieving optimum solar access.

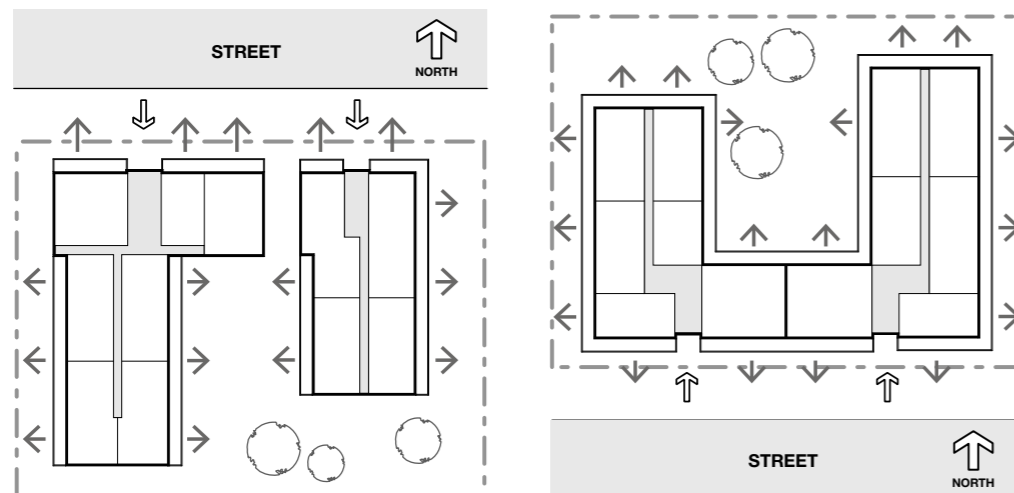

Plan diagram: Example orientation with good solar access.

2 Apply the cooling load caps for all apartments.

- GUIDANCE: Note this measure targets the worst performing 15% of dwellings in apartment buildings subject to excessive heat load over summer. The proportion of dwellings affected may be higher in buildings where site constraints mean that the majority of windows face east and west.

3 Reduce building cooling loads through design and construction responses.

→ GUIDANCE: Design techniques include:

- Reducing area of glazing for windows facing east or west will lower heat gains in summer (and reduce the cooling load), as well as lower heat losses in winter. Window size reduction will typically be the most cost effective straightforward means of reducing cooling loads.
- External sun shading and solar control devices should be integrated into the building design where possible. Vertical shading is suited to east and west aspects and horizontal shading to northern aspects. North facing sun shading should be designed to allow winter sun and shade summer sun. Adjustable external shading of windows allows for occupant control. This is effective in climates with highly variable weather.
- Maximising the use of effective natural ventilation. Cross ventilated apartments are also an effective means of reducing cooling loads. Refer to the natural ventilation standard.
- Hard floor surfaces allow the thermal mass of the floor to better moderate the impact of solar heat gain on the performance of the dwelling.
- Providing insulation on the outer side of building elements with high thermal mass materials like brick or concrete ensures they do not heat up as much in hot weather
- Selecting glazing with low Solar Heat Gain Coefficient (SHGC) particularly on the west and east where highest solar heat gain is experienced, will support thermal performance. Note, low solar heat gain glazing includes tinted and/or Low E coated glass with a maximum solar heat gain co-efficient of 0.4.
- Use of ceiling fans. Particularly in warmer climate zones these help the occupant at least delay the onset of cooling on hot days or avoid cooling altogether on milder days.

Supporting documentation

Provide the standard outputs from existing NatHERS tools. The NatHERS certificate provides verification of the cooling load performance.

Guidance to waste and recycling

Why this is important

Good waste management promotes recycling, protects the environment and addresses health and safety risks. Apartment developments with good waste management facilities minimise the impacts of waste on the health and wellbeing of occupants and the amenity of the public realm.

Application

Clause 55.07-11 (Waste and recycling) applies to apartment developments of four storeys or less (excluding a basement).

Clause 58.06-3 (Waste and recycling) applies to apartment developments of five or more storeys (excluding a basement) in a residential zone and all apartment developments in other zones.

Waste and recycling objectives (Clause 58.06-3 or Clause 55.07-11)

To ensure dwellings are designed to encourage waste recycling.

To ensure that waste and recycling facilities are accessible, adequate and attractive.

To ensure that waste and recycling facilities are designed and managed to minimise impacts on residential amenity, health and the public realm.

Standard (D23 or B45)

Developments should include dedicated areas for:

- Waste and recycling enclosures which are:
 - Adequate in size, durable, waterproof and blend in with the development.
 - Adequately ventilated.
 - Located and designed for convenient access by residents and made easily accessible to people with limited mobility.
- Adequate facilities for bin washing. These areas should be adequately ventilated.
- Collection, separation and storage of waste and recyclables, including where appropriate opportunities for on-site management of food waste through composting or other waste recovery as appropriate.
- Collection, storage and reuse of garden waste, including opportunities for on-site treatment, where appropriate, or off-site removal for reprocessing.
- Adequate circulation to allow waste and recycling collection vehicles to enter and leave the site without reversing.
- Adequate internal storage space within each dwelling to enable the separation of waste, recyclables and food waste where appropriate.

Waste and recycling management facilities should be designed and managed in accordance with a Waste Management Plan approved by the responsible authority and:

- Be designed to meet the best practice waste and recycling management guidelines for residential development adopted by Sustainability Victoria.
- Protect public health and amenity of residents and adjoining premises from the impacts of odour, noise and hazards associated with waste collection vehicle movements.

Decision guidelines

Before deciding on an application, the responsible authority must consider:

- The design response.
- Any relevant waste and recycling objective, policy or statement set out in this scheme.

Design guidance

- 1 **Prepare a Waste Management Plan (WMP) that details how different waste streams (including hard waste) will be stored and collected in the development.**
 - GUIDANCE: A waste management plan should be prepared by a suitably qualified waste consultant. The typical contents of a WMP are outlined under the supporting documentation. The responsible authority may have additional requirements.
 - GUIDANCE: The waste management plan should provide a clear method for storage, collection, and disposal of household waste, recyclables, green waste and hard waste.
- 2 **Provide bins suitably sized to accommodate all categories of waste. Provide a waste room that is sufficiently sized to accommodate all bins.**
 - GUIDANCE: Refer to local council waste management guidelines to determine required waste provision and information requirements.
 - GUIDANCE: Minimise the need for multiple collections over a week to reduce disruptive noise by providing adequate waste storage for weekly collection.
 - GUIDANCE: Provide adequate space to manoeuvre and access the bins to encourage tidy use and ease collection.
 - GUIDANCE: On floors where there are apartments that comply with the accessibility standards, common storage areas for waste and recyclables should be accessible for residents with limited mobility.
 - GUIDANCE: Where residents must access the basement or common storage areas to dispose of waste or recyclables, ensure that these areas are accessible for residents with limited mobility.
- 3 **Nominate waste collection vehicle size, access points and movement paths.**
 - GUIDANCE: Design access to waste storage areas to minimise the movement of waste collection vehicles to reduce traffic disruption and increase safety. Limiting reversing of trucks limits noise associated with reversing alarms.
 - GUIDANCE: Provide adequate clearance above collection points taking into account the height of collection vehicles while lifting bins.
 - GUIDANCE: Use swept path analysis to determine if a design will meet the manoeuvring requirements of the collection vehicle. It will also inform design responses to limit reversing of trucks and associated noise from reversing alarms.

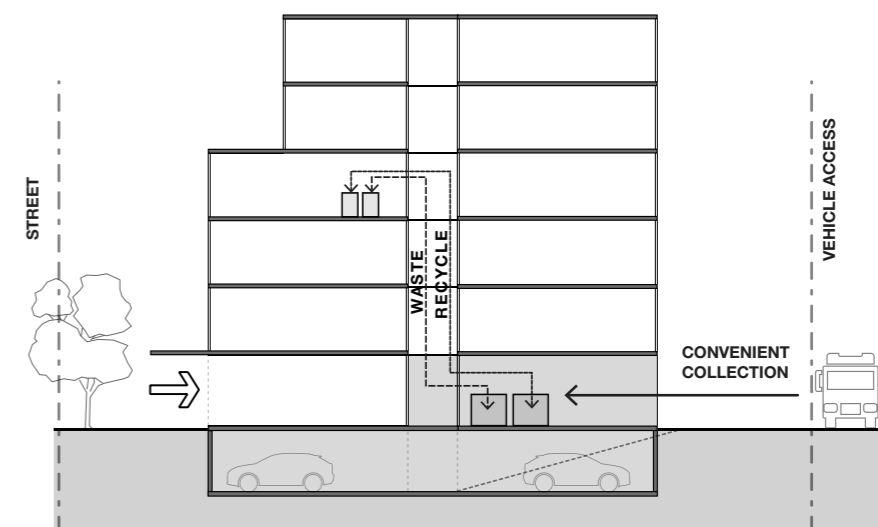

Waste and recycling management

4 Provide dual waste and recycling chutes (or equivalent system) in taller buildings with openings on each floor to provide convenient access for residents.

→ GUIDANCE: Waste chutes should be accessible from each level and located in a convenient, centrally located position, e.g. adjacent to the lift shaft.

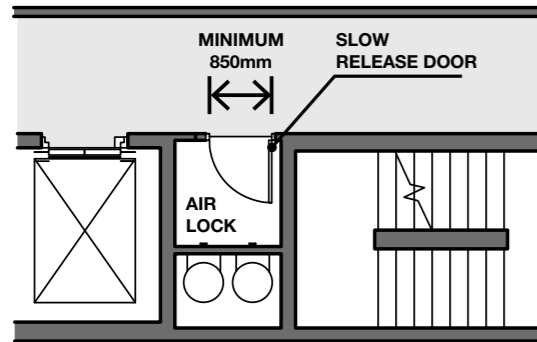

Section diagram. Airlock design for accessibility and amenity.

5 Design waste facilities to provide adequate drainage, noise and odour controls including provisions for a bin wash down area.

→ GUIDANCE: Provide adequate ventilation to the bin room to prevent the build-up of odours. Providing a bin wash down area to allow bins to be cleaned will prevent the generation of odours.

→ GUIDANCE: Ensure bin room drainage does not lead to stormwater pollution.

→ GUIDANCE: Locate the waste chutes, bin rooms and waste collection points to minimise noise impacts for residents and uses adjacent to the site. Use acoustic insulation to reduce noise impacts where waste chutes are provided.

Supporting documentation

Locate and dimension waste storage facilities on plans

Typical Checklist for a Waste Management Plan

When preparing a Waste Management Plan (WMP) complete and include the following checklist with the WMP.

Plan Element	Completed
Project details:	
• Site address	
• Development/ land use type	
• Number of storeys	
• Number of dwellings	
- 1 Bedroom	
- 2 Bedroom	
- 3 or more bedrooms	
• Floor area of any additional space types, e.g. communal facilities or commercial spaces.	
Estimated Waste Generation:	
• Waste generation rates of each waste type.	
• Waste generation for each space type	
• Total waste generation rates for the development	
Bin Requirements:	
• Volume and dimensions (relative to demand and aim to reduce collection frequency)	
• Number	
• Type and colour	

Plan Element	Completed
Waste Storage:	
• Size and location of waste room, and facilities at each floor level	
• Bin chutes (Design e.g. dual chute)	
• Odour, pest, noise, and pollution management	
• Description of how hard waste will be managed	
• Green waste management (and Food waste) (where applicable)	
• Description of any waste and recycling equipment used, e.g. compactors, carousels.	
Bin Collection:	
• Access points	
• Collection frequency and timing	
• Council/Private collection	
• Traffic and noise management (inc swept path analysis)	
Additional requirements:	
• Details on how waste management information will be distributed to residents	
• Signage	
• Scaled waste management drawings	
• Accessibility to waste rooms and receptacles for residents with limited mobility	

Guidance to integrated water and stormwater management

Why this is important

The water management standard aligns with objectives of the Victorian Government’s Water for Victoria plan which supports measures to make best use of all water sources, reduce pollution of waterways, minimise the contribution of stormwater runoff to localised flooding and support cooling and greening of urban environment in the face of a changing climate.

Application

Clause 55.07-5 (Integrated water and stormwater management) applies to apartment developments of four storeys or less (excluding a basement).

Clause 58.03-8 (Integrated water and stormwater management) applies to apartment developments of five or more storeys (excluding a basement) in a residential zone and all apartment developments in other zones.

Integrated water and stormwater management objectives (Clause 58.03-8 or Clause 55.07-5)

To encourage the use of alternative water sources such as rainwater, stormwater and recycled water.

To facilitate stormwater collection, utilisation and infiltration within the development.

To encourage development that reduces the impact of stormwater run-off on the drainage system and filters sediment and waste from stormwater prior to discharge from the site.

Standard (D13 or B39)

Buildings should be designed to collect rainwater for non-drinking purposes such as flushing toilets, laundry appliances and garden use.

Buildings should be connected to a non-potable dual pipe reticulated water supply, where available from the water authority.

The stormwater management system should be:

- Designed to meet the current best practice performance objectives for stormwater quality as contained in the Urban Stormwater – Best Practice Environmental Management Guidelines (Victorian Stormwater Committee 1999) as amended.
- Designed to maximise infiltration of stormwater, water and drainage of residual flows into permeable surfaces, tree pits and treatment areas.

Decision guidelines

Before deciding on an application, the responsible authority must consider:

- Any relevant water and stormwater management objective, policy or statement set out in this scheme.
- The design response.
- Whether the development has utilised alternative water sources and/or incorporated water sensitive urban design.
- Whether discharge from the site to the stormwater will adversely affect water quality entering the drainage system.
- The capacity of the drainage network to accommodate additional stormwater.
- Whether the stormwater treatment areas can be effectively maintained.

Design guidance

Interpreting the Standard

Stormwater is water which drains off the site and buildings and is discharged into waterways. It primarily consists of runoff rainwater and may contain particles, organic matter, litter, chemicals etc. that without treatment can pollute downstream waterways. Other water discharges from cooling units or basement pumps also need to be managed appropriately.

1 Reduce stormwater runoff from the lot to the minimum volume possible.

- GUIDANCE: Capture and use rainwater and stormwater to the maximum extent practicable (i.e. by maximising onsite retention) for non-potable uses including toilet flushing, clothes washing, garden watering and green roofs (where practical). Onsite detention of stormwater may also be integrated with rainwater collection to protect against localised flooding.
- GUIDANCE: Demand from one to two floors may be sufficient to utilise all collectable rainwater. Designing a tank system for prompt drawdown through increased internal use can assist with both improved pollutant reduction and minimising initial discharges during rainfall events (to reduce risk of localised flooding).
- GUIDANCE: Runoff from impervious services can be caught and filtered via suitable landscape design and treatment areas to clean and reduce discharges into waterways.

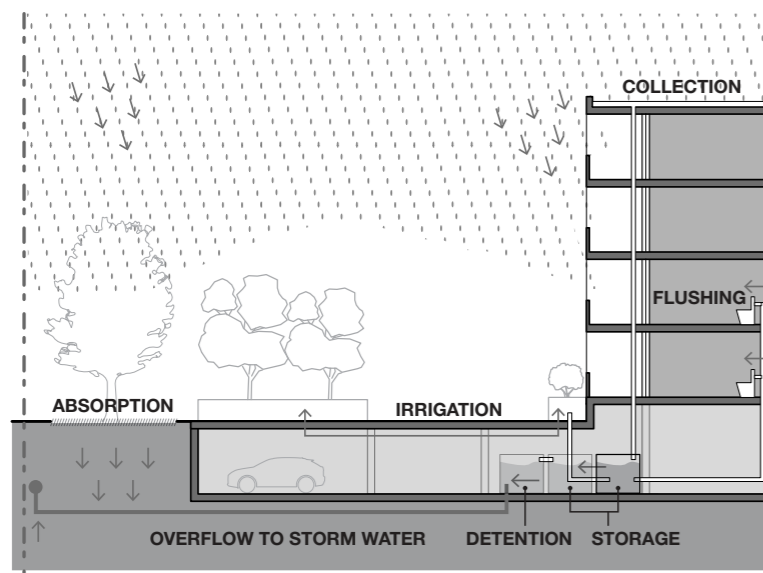

Section diagram. Integrated rainwater reuse and onsite detention.

2 Apply principles of water sensitive urban design (WSUD) to reduce the volume of stormwater runoff and to improve the quality of stormwater.

- GUIDANCE: Porous paving and rain gardens are practical measures suitable for most developments including constrained sites. Peak flow diversions to deal with storm events are necessary.
- GUIDANCE: Porous paving requires a basic maintenance regime (e.g., sweeping, vacuuming or high-pressure machine washing) to maintain effectiveness and should be designed to accommodate intended loading.
- GUIDANCE: Measures to buffer and slow the rate of discharge should be applied wherever possible. Design techniques include pavements with surface tapering towards tree plantings or use of swales and infiltration strips.
- GUIDANCE: Residual flows should be infiltrated into deep soil areas (See Landscape section) and filtered through garden areas and sediment traps.

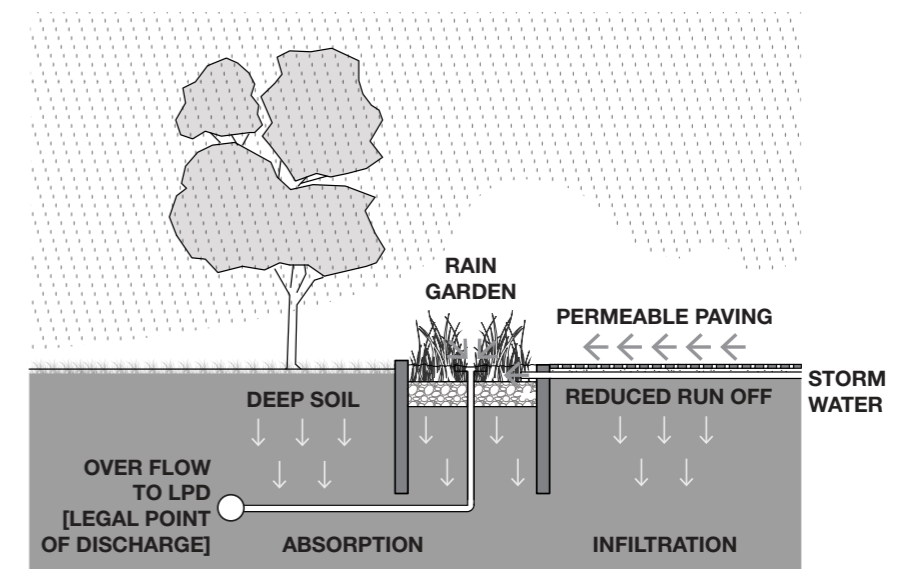

Section diagram. Permeable paving, rain gardens and deep soil reduce the volume and treat stormwater.

3 The storm water drainage system should be designed so that any overflow during heavy rain periods is safely conveyed to the legal point of discharge (LPD) to protect public safety and property.

4 Connect the apartment building to a reticulated recycled water supply (purple pipe) where available.

- GUIDANCE: This can operate in conjunction with retention and use of rainwater as part of an integrated approach.

Supporting documentation

Clear demonstration of how the design response meets the standards as a part of a sustainability management plan.

Outputs from software models used (such as MUSIC or the STORM calculator) to ensure good practice water and stormwater management. Suitable design tools for smaller developments include the STORM Calculator and for larger more complex sites modelling using MUSIC is appropriate.

Section 3 - Dwelling Amenity

Guidance to functional layout

Why this is important

Functional apartments have layouts that meet the needs of residents and room sizes and configurations appropriate for their intended use. Adaptable layouts provide for future household changes, which provides longevity of housing stock. The long-term needs of a community require a range of housing types so people of different ages, backgrounds and needs are provided for.

Application

Clause 55.07-12 (Functional layout) applies to apartment developments of four storeys or less (excluding a basement).

Clause 58.07-1 (Functional layout) applies to apartment developments of five or more storeys (excluding a basement) in a residential zone and all apartment developments in other zones.

Functional layout objective (Clause 58.07-1 or Clause 55.07-12)

To ensure dwellings provide functional areas that meet the needs of residents.

Standard (D24)

Bedrooms should:

- Meet the minimum internal room dimensions and area specified in [Table D7](#).
- Provide an area in addition to the minimum internal room dimensions and area to accommodate a wardrobe.

Table D7 Bedroom dimensions

Bedroom type	Minimum width	Minimum depth	Minimum area
Main bedroom	3 metres	3.4 metres	10.2 sqm
All other bedrooms	3 metres	3 metres	9 sqm

Living areas (excluding dining and kitchen areas) should meet the minimum internal room dimension and area specified in [Table D8](#).

Table D8 Living area dimensions

Dwelling type	Minimum width	Minimum area
Studio and 1 bedroom dwelling	3.3 metres	10 sqm
2 or more bedroom dwelling	3.6 metres	12 sqm

Decision guidelines

Before deciding on an application, the responsible authority must consider:

- The design response.
- The useability, functionality and amenity of habitable rooms

Design guidance

Interpreting the Standard

There is no restriction on how the width and depth dimensions are applied to a bedroom layout.

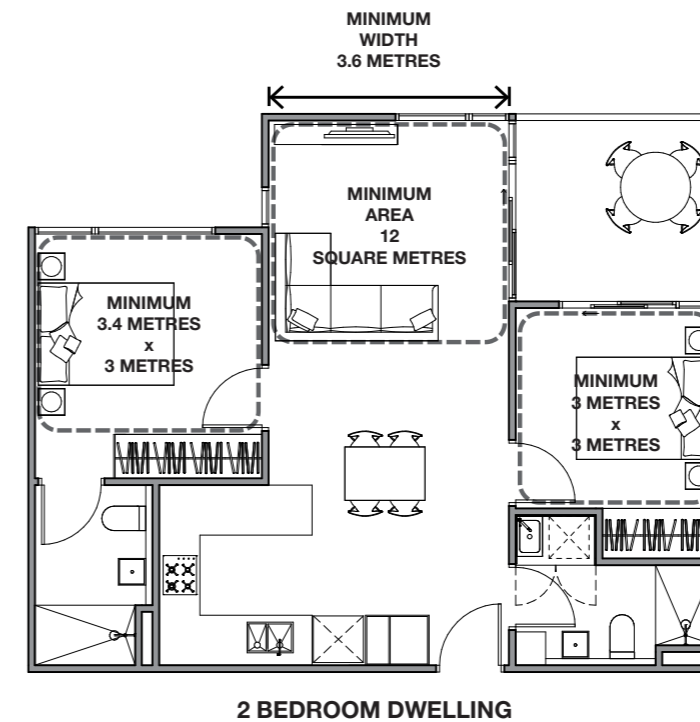

- 1 **Demonstrate usability and functionality of room configurations by including furniture layouts with realistically scaled furniture and adequate circulation space.**
 - GUIDANCE: Arrange rooms with efficient circulation and appropriate privacy between spaces.
 - GUIDANCE: Provide kitchen layouts with sufficient space for cooking, cleaning, food preparation and storage. Where dining is included within a kitchen, adequate bench space should be provided.

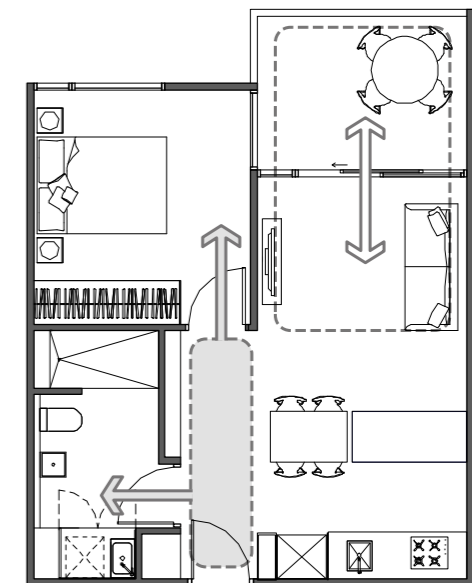

Plan diagram. Furnished layouts demonstrate the function of the rooms.

2 Apartment layouts which propose irregularly shaped or atypical spaces, need to demonstrate functionality and usability of the design with realistically scaled furniture and circulation.

- GUIDANCE: Use standard bed sizes and allow for a functional circulation path.
 - GUIDANCE: Demonstrate that areas for dining provide for functional seating arrangements appropriate to the apartment size and number of bedrooms.
-

Supporting documentation

Provide dimensioned plans showing minimum depth, width and area outline of bedrooms and the living room.

Guidance to room depth

Why this is important

Room depth and height determine the amount and quality of daylight penetration from a window.

Adequate daylight is important for occupant health and energy efficiency.

Application

Clause 55.07-13 (Room depth) applies to apartment developments of four storeys or less (excluding a basement).

Clause 58.07-2 (Room depth) applies to apartment developments of five or more storeys (excluding a basement) in a residential zone and all apartment developments in other zones.

Room depth objective (Clause 58.07-2 or Clause 55.07-13)

To allow adequate daylight into single aspect habitable rooms.

Standard (D25 or B47)

Single aspect habitable rooms should not exceed a room depth of 2.5 times the ceiling height.

The depth of a single aspect, open plan, habitable room may be increased to 9 metres if all the following requirements are met:

- The room combines the living area, dining area and kitchen.
- The kitchen is located furthest from the window.
- The ceiling height is at least 2.7 metres measured from finished floor level to finished ceiling level. This excludes where services are provided above the kitchen.

The room depth should be measured from the external surface of the habitable room window to the rear wall of the room.

Decision guidelines

Before deciding on an application, the responsible authority must consider:

- The design response.
- The extent to which the habitable room is provided with reasonable daylight access through the number, size, location and orientation of windows.
- The useability, functionality and amenity of the dwelling based on layout, siting, size and orientation of habitable rooms.
- Any overhang above habitable room windows that limits daylight access.

Design guidance

Interpreting the Standard

Depth is measured at the deepest point of the room where a room has an irregular shape.

The depth of cupboards should be included within the room depth dimension.

Refer to the National Construction Code for minimum ceiling heights for habitable rooms.

Where a habitable room is an open plan layout (combined living area, dining area and kitchen) with a ceiling height of 2.7m, the room depth can be extended to 9m as described in the standard above.

Where habitable rooms have a ceiling height of 2.4m the maximum room depth is 6m (2.5 x 2.4m).

Where habitable rooms have a ceiling height of 2.7m the maximum room depth is 6.75m (2.5 x 2.7m).

- 1 Increase the size and head height of windows to improve the daylight penetration into the depth of the room.

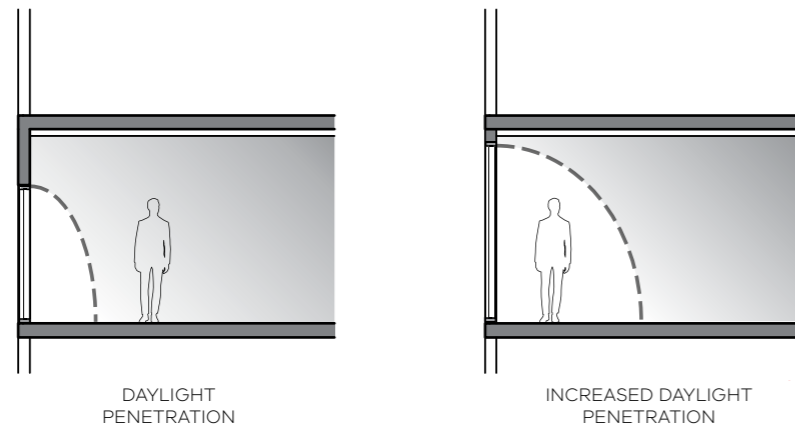

- 2 Allow for sufficient structural floor to floor heights to achieve required ceiling heights for the room depth.

→ GUIDANCE: Allow space for services and insulation between the ceiling and structure.

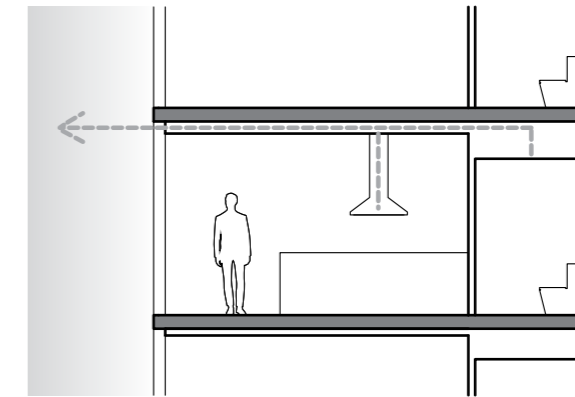

Section diagram. Ceiling space for services and insulation.

- 3 Configure balconies to suit the orientation of the apartment and increase daylight while controlling sunlight.

→ GUIDANCE: Large continuous overhangs beyond a single aspect room of 9m depth should be avoided

Refer to private open space for guidance on balcony configurations

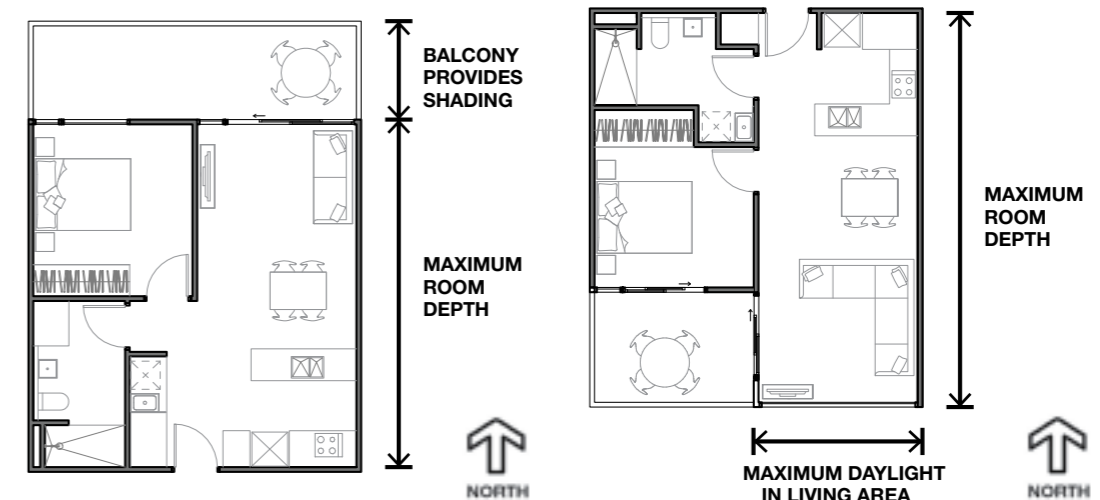

Plan diagram. Balconies can be configured and located to improve internal daylight.

Supporting documentation

Provide dimensions of habitable room depths.

Guidance to windows

Why this is important

Windows provide access to natural daylight, direct sunlight and airflow into habitable rooms of apartments, contributing to the health and wellbeing of occupants. They can reduce energy use by enabling occupants to go about their daytime activities without using artificial lighting. Daylight conditions vary according to the time of day, the season and the weather. Apartments should preferably let in direct sunlight: it helps make the living environment pleasant and reduces energy use by providing passive heat in cooler weather.

Application

Clause 55.07-14 (Windows) applies to apartment developments of four storeys or less (excluding a basement).

Clause 58.07-3 (Windows) applies to apartment developments of five or more storeys (excluding a basement) in a residential zone and all apartment developments in other zones.

Windows objective (Clause 58.07-3 or Clause 55.07-14)

To allow adequate daylight into new habitable room windows.

Standard (D26 or B48)

Habitable rooms should have a window in an external wall of the building.

A window may provide daylight to a bedroom from a smaller secondary area within the bedroom where the window is clear to the sky.

The secondary area should be:

- A minimum width of 1.2 metres.
- A maximum depth of 1.5 times the width, measured from the external surface of the window.

Decision guidelines

Before deciding on an application, the responsible authority must consider:

- The design response.
- The extent to which the habitable room is provided with reasonable daylight access through the number, size, location and orientation of windows.
- The useability and amenity of the dwelling based on the layout, siting, size and orientation of habitable rooms.

Design guidance

Interpreting the standard

The functional areas of habitable rooms including living areas should be located directly adjacent to the window on an external wall.

Borrowed light arrangements (where a room borrows light via an opening to another room) do not meet the standard.

Refer to further the National Construction Code for minimum window requirements for habitable spaces.

Snorkel arrangements can only be provided for bedrooms. The maximum depth (1.5 x width) control applies to the secondary area within the room.

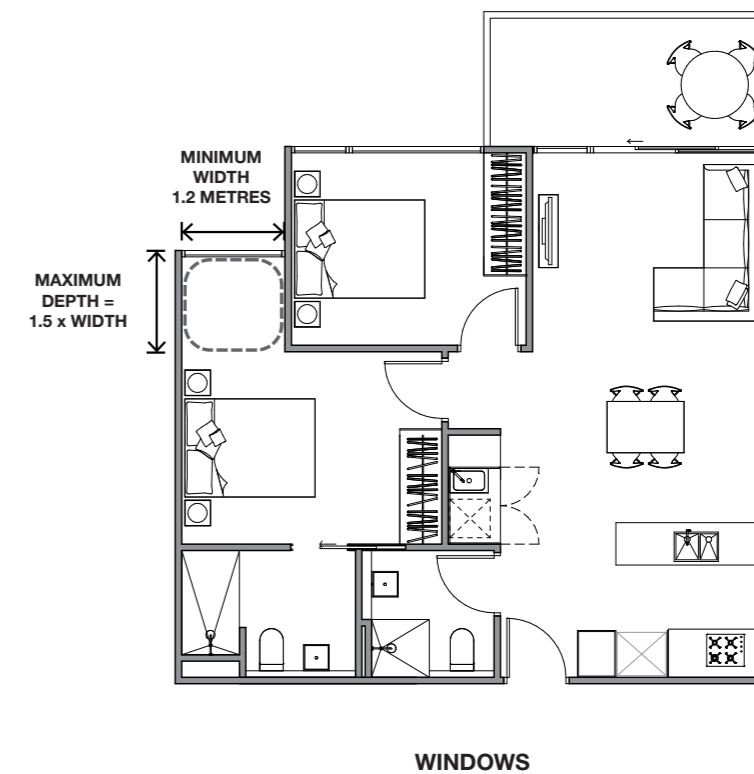

1 Design the window type, size, glazing selection, orientation and placement to respond to the site context and to optimise daylight.

→ GUIDANCE: Factors to consider include:

- Access to and control of direct sunlight through orientation and shading
- Access to daylight due to surrounding buildings for example in built up urban locations
- Optimising views and outlook while protecting privacy
- Opportunities for natural ventilation and the direction of prevailing breezes
- Impact of low amenity interfaces with exposure to noise, pollution and poor outlook.

2 Design windows and other openings to balance privacy with daylight and outlook.

→ GUIDANCE: Using raised sills or semi- solid balustrades protects privacy into spaces from below while allowing views out

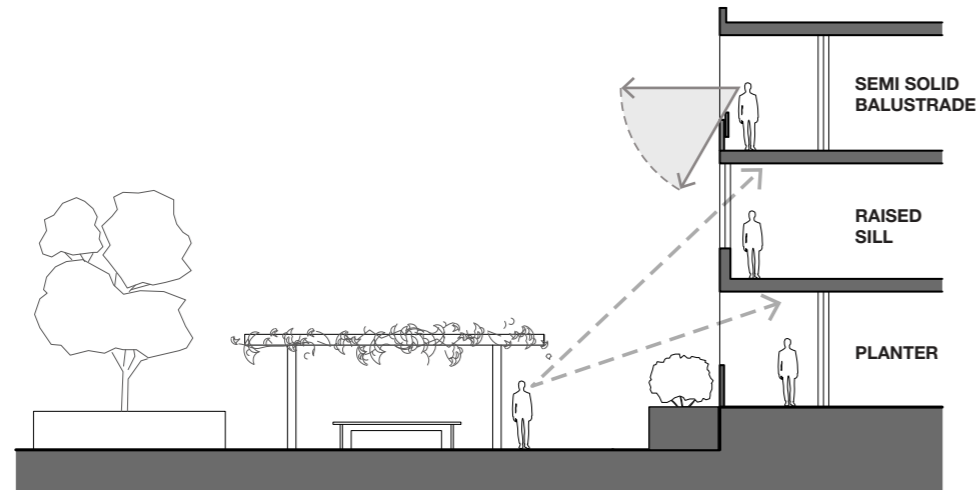

Section diagram. Design techniques to balance outlook and privacy.

3 Skylights may be used to contribute to daylight but should not provide the only source of daylight into a habitable room.

Supporting documentation

Include dimensions for bedrooms which access daylight via a smaller space within the room to demonstrate compliance with the standard.

Guidance to storage

Why this is important

Having access to convenient, accessible and secure storage improves the functionality of apartments.

Application

Clause 55.07-10 (Storage) applies to apartment developments of four storeys or less (excluding a basement).

Clause 58.05-4 (Storage) applies to apartment developments of five or more storeys (excluding a basement) in a residential zone and all apartment developments in other zones.

Storage objective (Clause 58.05-4 or Clause 55.07-10)

To provide adequate storage facilities for each dwelling.

Standard (D20 or B44)

Each dwelling should have convenient access to usable and secure storage space.

The total minimum storage space (including kitchen, bathroom and bedroom storage) should meet the requirements specified in [Table D6](#).

Decision guidelines

Before deciding on an application, the responsible authority must consider:

- The design response.
- The usability, functionality and location of storage facilities provided for the dwelling.

Table D6 Storage

Dwelling type	Total minimum storage volume	Minimum storage volume within the dwelling
Studio	8 cubic metres	5 cubic metres
1 bedroom dwelling	10 cubic metres	6 cubic metres
2 bedroom dwelling	14 cubic metres	9 cubic metres
3 or more bedroom dwelling	18 cubic metres	12 cubic metres

Design guidance

Interpreting the Standard

The total minimum storage volume in Table D6 includes the minimum storage volume within a dwelling.

Whitegoods and appliances such as refrigerators, ovens, dishwashers and washing machines should have dedicated spaces and are not included in the calculation of storage.

Spaces for bicycle and car parking are additional to the storage space requirements in Table D6.

1 Provide practical arrangement of storage appropriate to each space within the dwelling.

→ GUIDANCE: A minimum of 1.8 meters of robe length for the main bedroom and a 1.5 meters for all other bedrooms is practical for clothes storage.

→ GUIDANCE: As a rule of thumb, storage volumes (m³) per linear meter of cupboards are as follows:

For 600mm deep cupboards

- 750mm bench height = 0.45m³
- 2400mm full height = 1.44m³

For 300mm deep cupboards

- 750mm overhead cupboard = 0.225m³

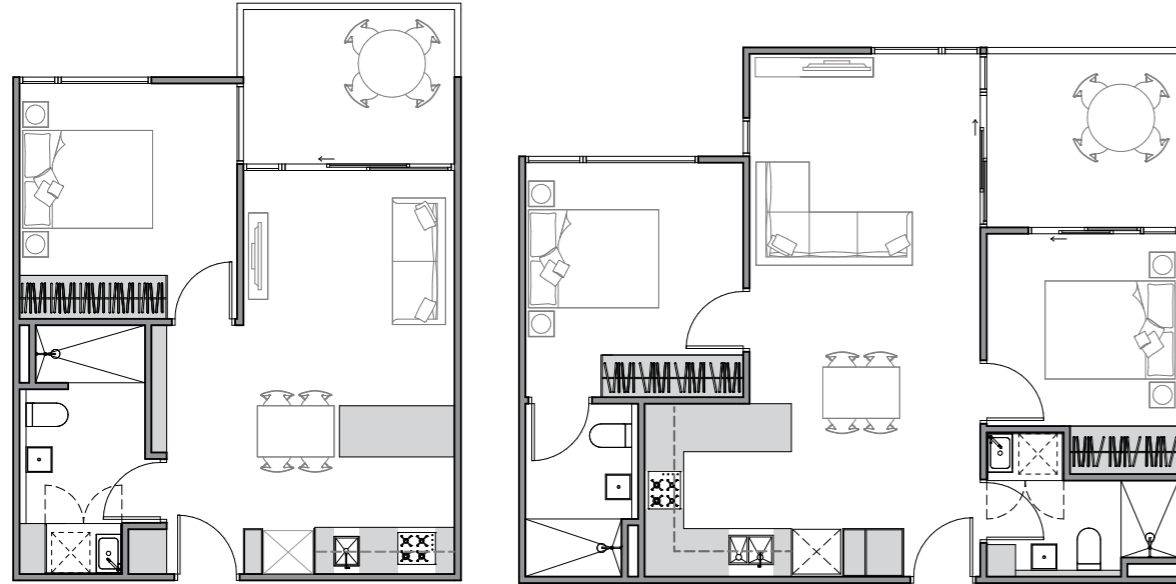

Plan diagram. Examples of storage areas in typical 1 bed and 2 bed layouts.

2 Long term storage provided externally to an apartment can be provided in basements and car parking areas, or in a common area convenient to the apartment.

→ GUIDANCE: Dedicated storage rooms can make use of areas within the floor plate which have limited access to natural light and ventilation

→ GUIDANCE: Locate lockable storage in locations with good informal surveillance to improve security as they are prone to theft

→ GUIDANCE: Dedicated storage lockers in basements are preferred as they provide easier access when compared to over car bonnet storage

→ GUIDANCE: Make storage enclosures a functional shape and size to suit various needs such as storing bulky items.

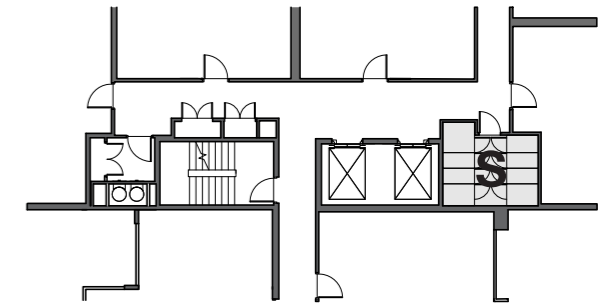

Plan diagram. Long term storage convenient to apartments.

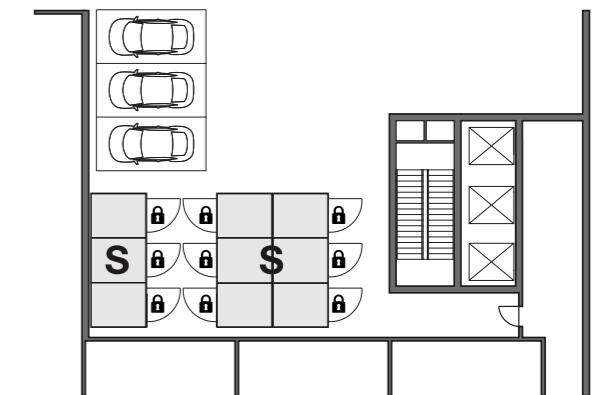

Plan diagram. Long term storage in a car park area.

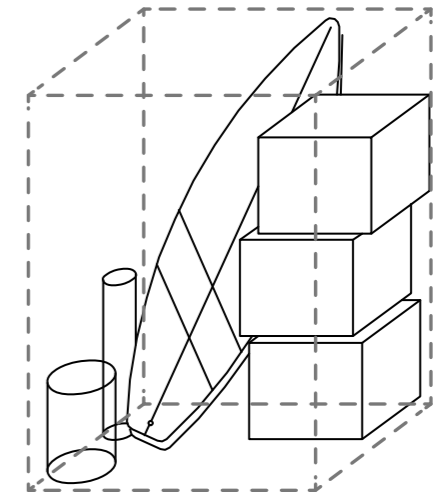

Functional long term storage volume.

Supporting documentation

Provide a schedule with a breakdown of minimum internal and external storage provisions for each apartment type.

Guidance to natural ventilation

Why this is important

Natural ventilation is the movement and change of fresh air in internal spaces by natural means using windows that can be opened.

Cross ventilation is the movement of air through an internal space (or spaces) between one external opening and another.

Fresh air movement through an apartment is important because it contributes to thermal comfort, increases passive cooling opportunities and creates a comfortable and healthy indoor environment.

Application

Clause 55.07-15 (Natural ventilation) applies to apartment developments of four storeys or less (excluding a basement).

Clause 58.07-4 (Natural ventilation) applies to apartment developments of five or more storeys (excluding a basement) in a residential zone and all apartment developments in other zones.

Natural ventilation objectives (Clause 58.07-4 or Clause 55.07-15)

To encourage natural ventilation of dwellings.

To allow occupants to effectively manage natural ventilation of dwellings.

Standard (D27 or B49)

The design and layout of dwellings should maximise openable windows, doors or other ventilation devices in external walls of the building, where appropriate.

At least 40 per cent of dwellings should provide effective cross ventilation that has:

- A maximum breeze path through the dwelling of 18 metres.
- A minimum breeze path through the dwelling of 5 metres.
- Ventilation openings with approximately the same area.

The breeze path is measured between the ventilation openings on different orientations of the dwelling.

Decision guidelines

Before deciding on an application, the responsible authority must consider:

- The design response.
- The size, orientation, slope and wind exposure of the site.
- The extent to which the orientation of the building and the layout of dwellings maximises opportunities for cross ventilation.
- Whether an alternative design meets the relevant objectives having regard to the amenity of the dwelling and the site context.

Design guidance

Interpreting the standard

A breeze path is measured as a sequence of straight line segments measured from the centreline of openings.

A minimum of one breeze path needs to be nominated.

Refer to the National Construction Code further guidance for minimum ventilation requirements.

1 Configure floorplates with corner or through apartments to achieve effective cross ventilation.

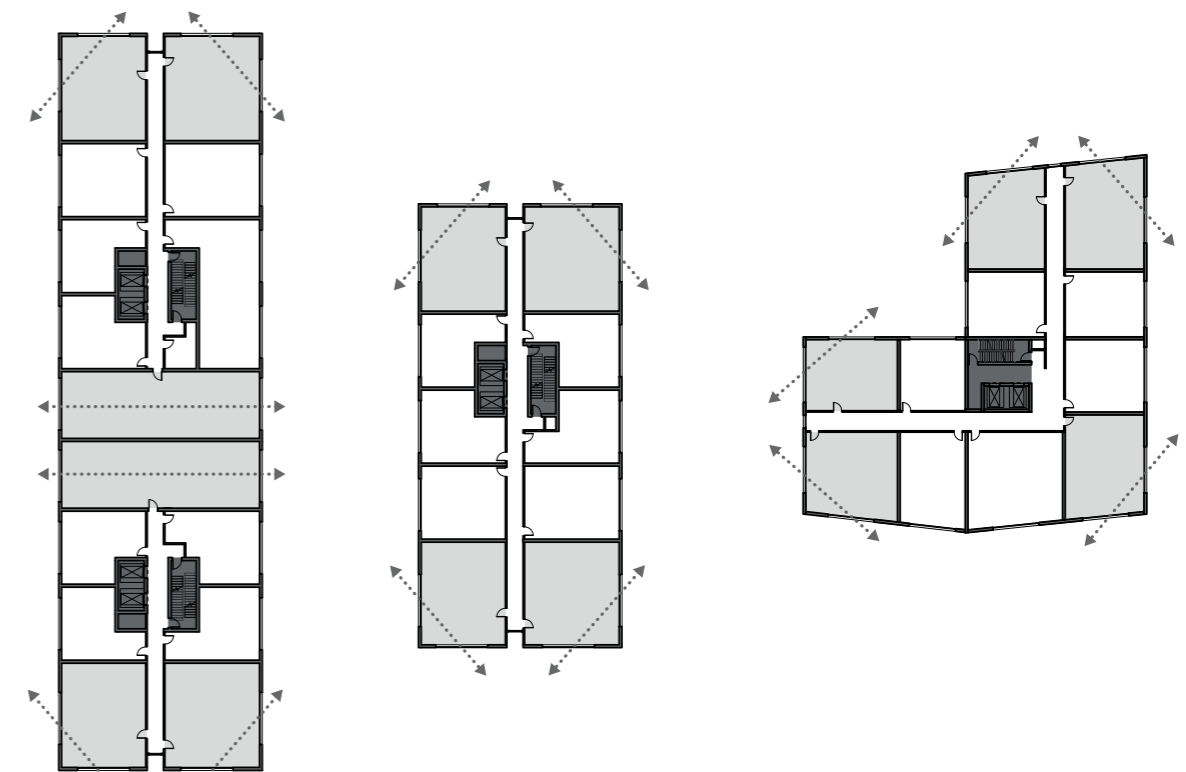

Plan diagram. Floorplates allowing for cross ventilation.

2 Wherever possible, provide openable windows or doors into habitable rooms to achieve natural air flow.

→ GUIDANCE: Effective natural ventilation is influenced by:

- the clear openable area of varied window types
- prevailing wind conditions and air pressures
- temperature differentials
- the surrounding built environment
- the length of breeze path and number of obstructions through an apartment.

→ GUIDANCE: Use the urban context report of prevailing winds to ensure that opportunities for natural air flow are maximised.

→ GUIDANCE: Tall buildings may be constrained from providing openable windows at higher levels due to environmental factors.

3 Locate and design windows that are on different orientations of a dwelling to provide cross ventilation with optimal breeze paths.

- GUIDANCE: Effective cross ventilation is achieved when the inlet and outlet have approximately the same area allowing air to be drawn through the apartment using opposite air pressures on each side of the building.
- GUIDANCE: An effective breeze path should minimise the number of doors and obstructions along the breeze path.

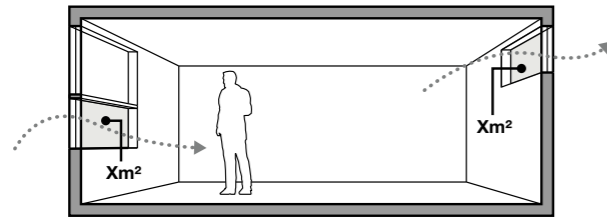

Section diagram. Breeze path showing.

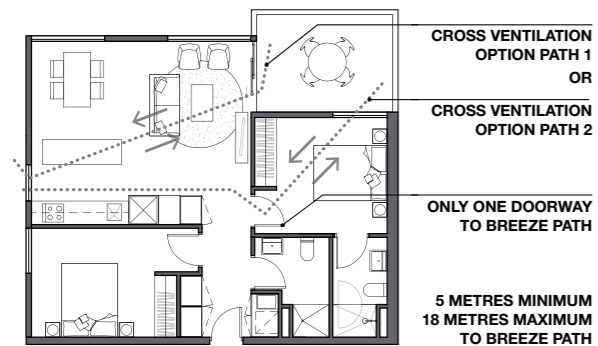

Plan diagram. Examples of measuring breeze path length.

4 An adequately sized operable roof light in a single aspect apartment may achieve cross ventilation where adequate air flow can be demonstrated by engineering analysis.

- GUIDANCE: Roof lights should be designed to be weather protected, secure and maintain good thermal performance.

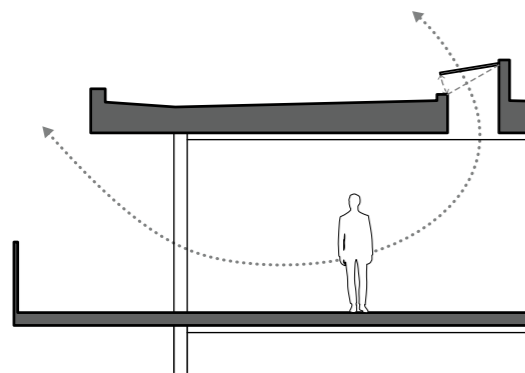

Elevation diagram. Roof lights can provide cross ventilation.

5 Demonstrate alternative effective ventilation solutions where cross ventilation is constrained, for example, by consistently high wind conditions or heritage or adaptive reuse of existing buildings.

Supporting documentation

Nominate on a plan which apartments are cross ventilated and illustrate the location and length of the breeze path, or provide a ventilation report for an alternative solution.

Guidance to private open space

Why this is important

Access to functional and usable private open spaces — outdoor spaces such as balconies, courtyards and terraces, accessible only to the particular apartment — allows occupants to extend their living spaces outdoors to enjoy a variety of recreations.

Balconies on taller buildings can be unpleasant, so the apartment standards provide flexibility to provide internal spaces instead (such as extra sitting areas, study areas and play areas for children).

Application

Both Clause 55.05-4 (Private open space) and Clause 55.07-9 (Private open space above ground floor) apply to apartment developments of four storeys or less (excluding a basement).

Clause 58.05-3 (Private open space) applies to apartment developments of five or more storeys (excluding a basement) in a residential zone and all apartment developments in other zones.

Note: For simplicity, only the Objective and Standard relating to Clause 58.05-3 is shown below.

Private open space objective (Clause 58.05-3)

To provide adequate private open space for the reasonable recreation and service needs of residents.

Standard (D19)

A dwelling should have private open space consisting of at least one of the following:

- An area at ground level of at least 25 square metres, with a minimum dimension of 3 metres and convenient access from a living room.
- A balcony with at least the area and dimension specified in [Table D5](#) and convenient access from a living room.
- An area on a podium or other similar base of at least 15 square metres, with a minimum dimension of 3 metres and convenient access from a living room.
- An area on a roof of 10 square metres, with a minimum dimension of 2 metres and convenient access from a living room.

If a cooling or heating unit is located on a balcony, the minimum balcony area specified in [Table D5](#) should be increased by at least 1.5 square metres.

If the finished floor level of a dwelling is 40 metres or more above ground level, the requirements of [Table D5](#) do not apply if at least the area specified in [Table D6](#) is provided as living area or bedroom area in addition to the minimum area specified in [Table D7](#) or [Table D8](#) in [Standard D24](#).

Table D5: Balcony size

Orientation of dwelling	Dwelling type	Minimum area	Minimum dimension
North (between north 20 degrees west to north 30 degrees east)	All	8 square metres	1.7 metres
South (between south 30 degrees west to south 20 degrees east)	All	8 square metres	1.2 metres
Any other orientation	Studio or 1 bedroom dwelling	8 square metres	1.8 metres
	2 bedroom dwelling	8 square metres	2 metres
	3 or more bedroom dwelling	12 square metres	2.4 metres

Table D6: Additional living area or bedroom area

Dwelling type	Additional Area
Studio or 1 bedroom dwelling	8 square metres
2 bedroom dwelling	8 square metres
3 or more bedroom dwelling	12 square metres

Decision guidelines

Before deciding on an application, the responsible authority must consider:

- The design response.
- The usability and functionality of the private open space, including its size and accessibility.
- The amenity of the private open space based on the orientation of the lot, noise exposure, the wind conditions and the sunlight it will receive.
- The availability of and access to public or communal open space.
- The usability and functionality of any additional living area or bedroom area, including its size and layout.

Design guidance

Interpreting the standard

To improve liveability, minimum balcony sizes vary according to the orientation of the apartment.

Minimum balcony sizes vary according to the solar access to an apartment. This is to minimise overshadowing of living areas, which will improve a home’s energy efficiency.

New north- and south-facing apartments can have narrower (but longer) balconies than east- or west-facing apartments.

Balconies can be larger than the minimum sizes.

The reason for this variation in balcony sizes is because:

- a narrow balcony above a north-facing window protects the apartment from summer sun and allows good winter sun, which may reduce the need for heating and lighting
- a south-facing window that has no balcony overhead receives more daylight in winter, which may reduce the need for lighting
- east- and west-facing apartments are not affected by overshadowing from a balcony overhead, so they can have deep balconies.

An apartment’s orientation influences minimum balcony areas and dimensions

These illustrations show examples of the minimum sizes of balconies according to an apartment’s orientation, in line with [Table D5](#).

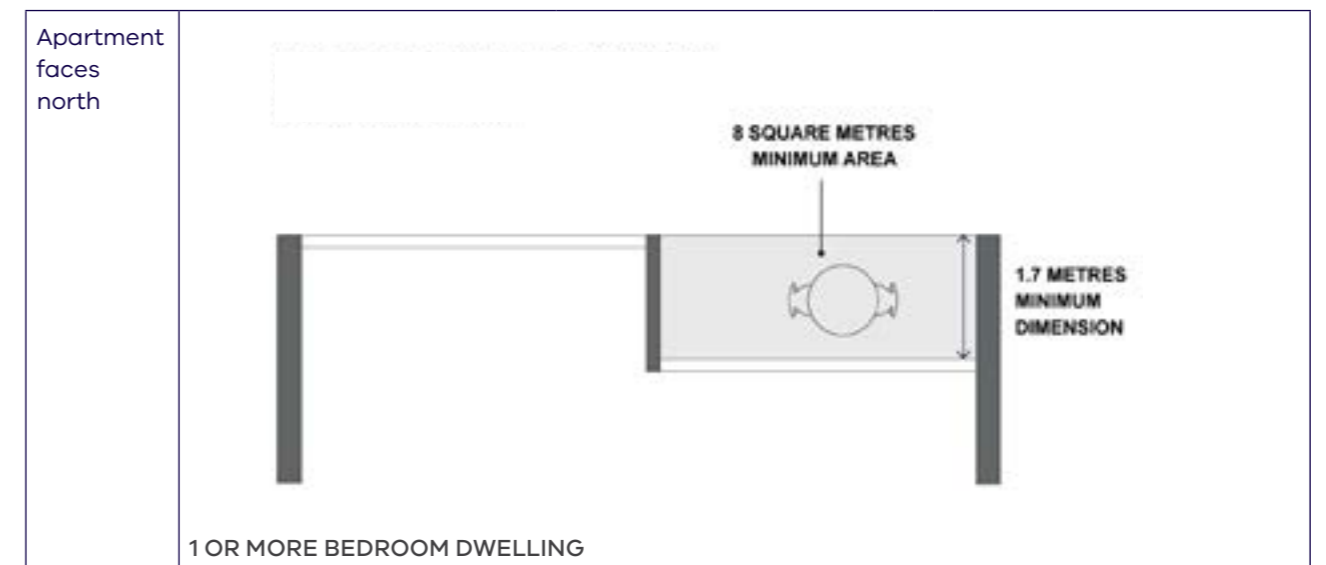

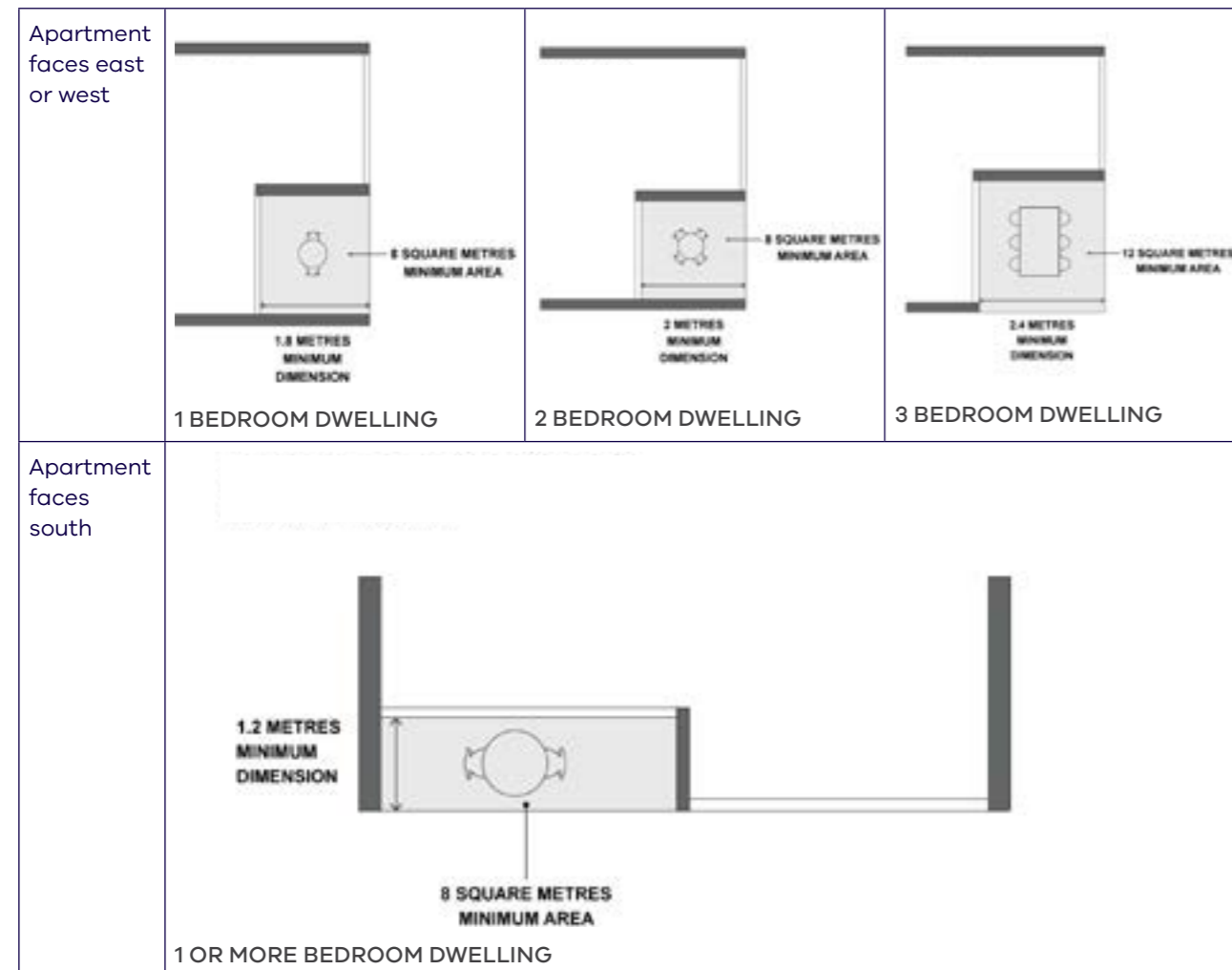

Where site conditions constrain the use of balconies on the upper levels of taller buildings, compensate by providing extra space in the living area or bedroom.

At a height of 40 metres or more from the ground level, the balcony can be replaced with extra space in the living area or bedrooms to support work, play, utility and storage.

The height of 40 metres — 13 storeys — means that balconies are provided at the lower levels of apartment buildings, which contributes to the streetscape.

If a balcony is being replaced with extra space in the living area or bedrooms, it needs to be in addition to the minimum areas required under functional layout Standard D24.

The extra space to be provided in the living area or bedrooms if there is no balcony is for:

- a north- or south-facing apartment: 8 square metres
- an east- or west-facing apartment: 8–12 square metres, depending on the number of bedrooms in the apartment.

The internal space replacing a balcony can be provided in multiple locations in the living area and/or bedrooms.

For amenity, the space should be part of the living area or bedroom space or be an alcove or a joinery unit that opens to the living area or bedroom.

The standard allows the flexibility to not provide balconies on any or all sides of a building (for example, due to noise, winds or lack of sunlight).

Measuring private open space abutting gardens and odd-shaped balcony sizes

Planting areas are included in the measurement of ground-floor private open space. The clear usable space should have the minimum dimension and areas shown in [Table D5](#).

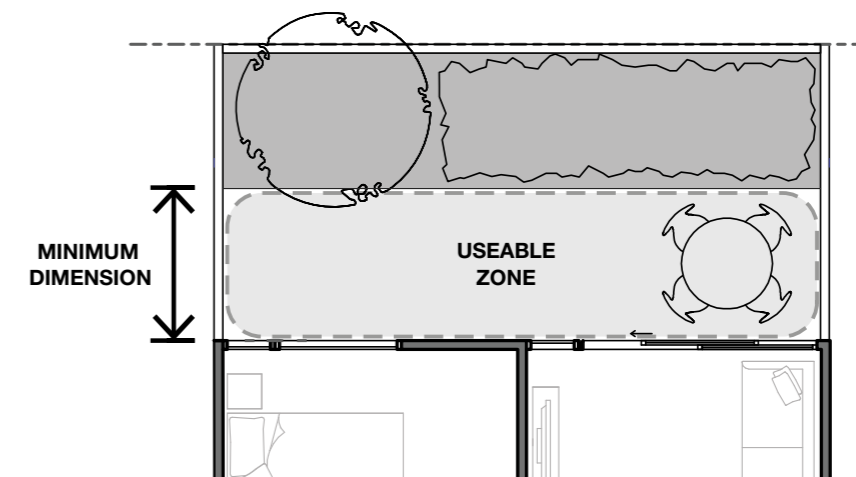

Plan diagram. Planting areas are included in ground floor private open spaces with a clear usable space which meets the minimum dimension and areas shown in [Table D5](#).

Measuring odd-shaped balcony sizes

Where irregularly shaped balconies are proposed, only the portion of the balcony which meets the minimum

dimension will be calculated towards the minimum area.

The minimum area must be provided in a single usable space. Other balcony areas may be provided in addition.

The additional area for an air conditioning unit does not need to meet the minimum balcony dimension: it can be a smaller dimension.

Where storage is integrated into the balcony design, it is not included in the minimum area requirements.

Wintergardens can be counted as private open space, providing they do not compromise adequate daylight and ventilation to the dwelling. Where planting areas are included in ground floor, podium or rooftop private open spaces, provide a clear usable space which meets the minimum dimensions and areas included in [Table D5](#).

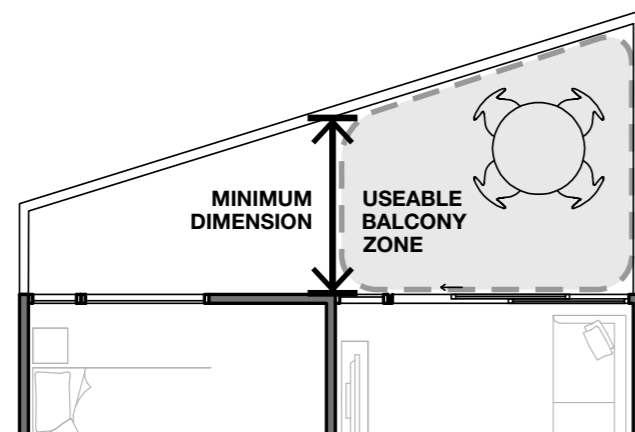

Plan diagram. The minimum area provided in a single usable space.

1 Configure balconies to support other internal apartment amenity objectives.

→ GUIDANCE: design ideas include:

- Inset balconies, rather than projecting balconies, provide greater wind protection.
- Limiting the depth of north- and south-facing balconies optimises the energy efficiency of the apartments below.
- Inset balconies to allow living rooms to be located at the building edge (which increases daylight to the room), but still consider the need for summer sun protection according to orientation.
- Locate balconies to avoid exposure to noise sources.
- Wintergardens reduce exposure to noisy conditions.

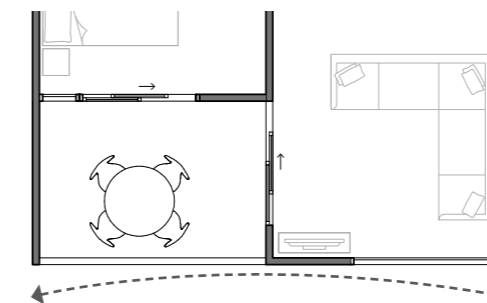

Plan diagram. Inset balconies can reduce exposure in windy conditions.

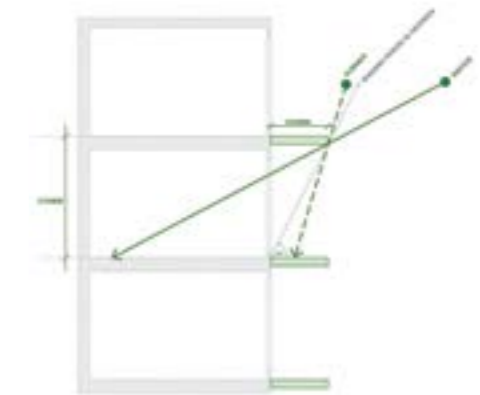

Section diagram. Narrow north-facing balconies improve winter sun access while still providing summer shading.

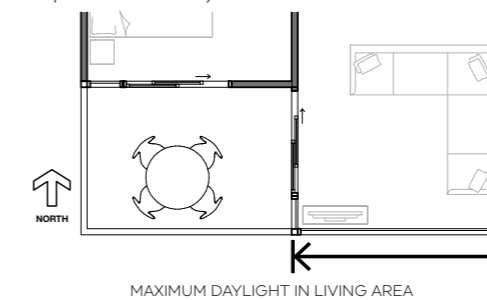

Plan diagram. Increasing daylight into living areas.

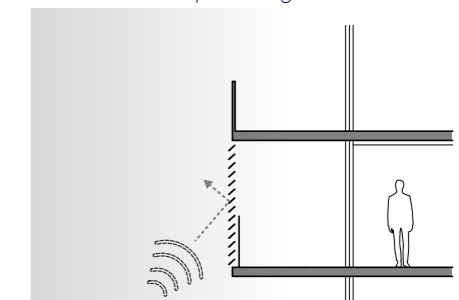

Section diagram. Wintergardens provide protection in windy conditions.

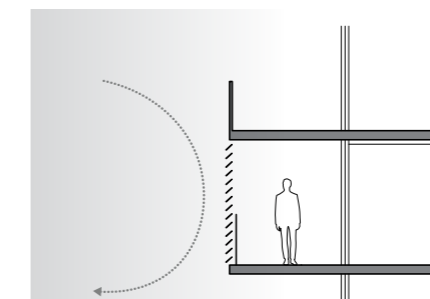

Section diagram. Wintergardens provide protection from noise.

2 For north- and south-facing apartments, run narrower balconies across the living area and bedroom to connect the indoor and outdoor spaces.

→ GUIDANCE: If narrower balconies are going to be provided on north- and south-facing apartments, making a long balcony will deliver the required minimum balcony area.

→ DESIGN IDEAS include:

- Extending the balcony in front of the bedroom as well as the living room on the north or south side of the building, to provide some outdoor space accessed from those rooms.

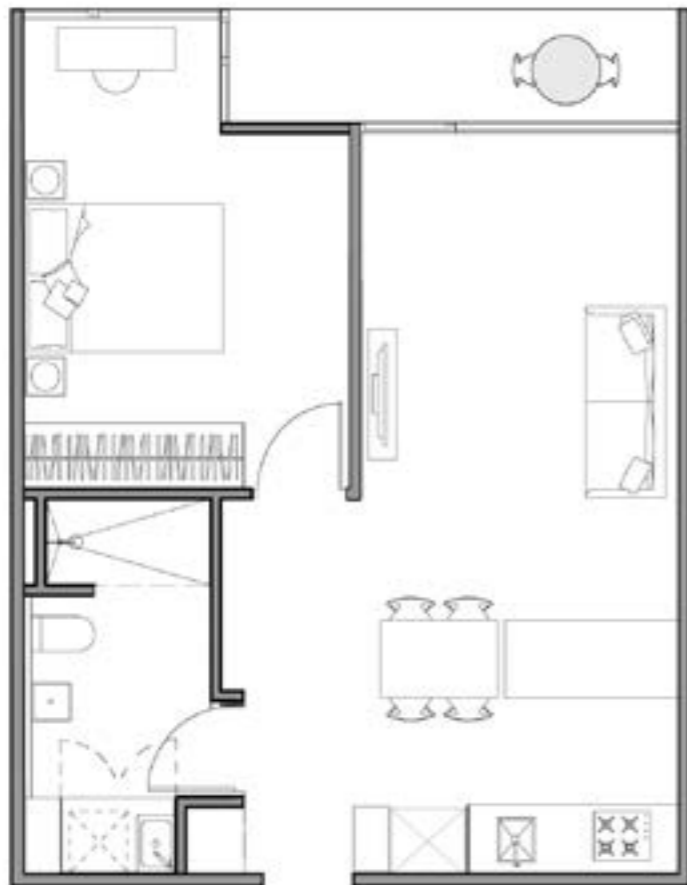

Plan diagram: Narrow balcony extending in front of living area and bedroom area.

3 For taller buildings — where the urban context and site layout constrain provision of outdoor private open space (balconies) — provide extra space inside: in the living area or bedroom.

→ GUIDANCE: Examples of constrained situations include high-wind conditions, proximity to high noises and adaptive reuse of existing buildings.

→ GUIDANCE: Useful space that can be added to an apartment includes a study, play or exercise area, extra storage space or a ventilated drying and utility space.

→ DESIGN IDEAS include:

- space in the living room (such as more seating or a day bed) for socialising or relaxing
- deep window ledges in the bedroom and/or living room for seating, relaxing or for a play area for children
- space for children's play or home exercise (such as yoga, weights or cardio equipment)
- a concealed utility space with access to light and natural ventilation to store mops and other household equipment, a pet toilet and/or a dedicated laundry and drying space
- space in the living area or bedroom to work from home or a secluded, built-in desk in an alcove
- space in the living area for a bike, storage for other equipment or shelves for books or household items.



Plan A. Additional living area (with 8 square metres dimension).



Plan B. Additional bedroom area (with 8 square metres dimension).

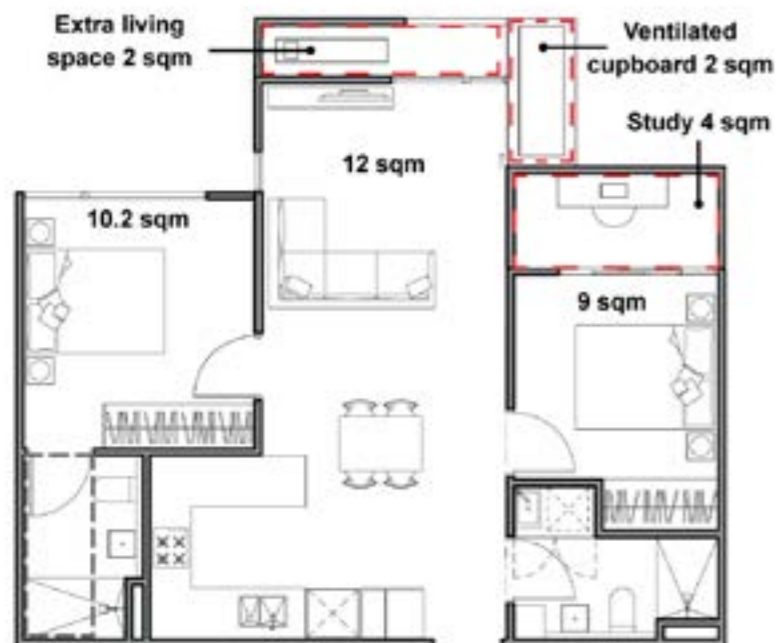

Plan C. Additional utility area (including extra living, study, and storage space) (with total 8 square metres dimension)

Guidance to accessibility

Why this is important

Accessibility in design promotes equal access to apartments for all community members including those with limited mobility, families with young children and older people. Apartments which comply with the accessibility standard can be easily altered to meet changing needs of residents and ensures housing stock caters for a diverse range of household types over time.

Application

Clause 55.05-6 (Accessibility) applies to apartment developments of four storeys or less (excluding a basement).

Clause 58.05-1 (Accessibility) applies to apartment developments of five or more storeys (excluding a basement) in a residential zone and all apartment developments in other zones.

Accessibility objective (Clause 58.05-1 or Clause 55.05-6)

To ensure the design of dwellings meets the needs of people with limited mobility.

4 Where the urban context and site layout constrain the provision of private open space, compensate with increased areas of communal open space.

→ GUIDANCE: Examples of constrained situations include high-wind conditions, proximity to high noises and adaptive reuse of existing buildings.

Supporting documentation

Provide minimum dimensions and areas to all private open spaces. Include any extra space in the living area or bedrooms to replace a balcony.

Standard (D17 or B41)

At least 50 per cent of dwellings should have:

- A clear opening width of at least 850mm at the entrance to the dwelling and main bedroom.
- A clear path with a minimum width of 1.2 metres that connects the dwelling entrance to the main bedroom, an adaptable bathroom and the living area.
- A main bedroom with access to an adaptable bathroom.
- At least one adaptable bathroom that meets all of the requirements of either Design A or Design B specified in Table D4.

Table D4 Bathroom design

	Design option A	Design option B
Door opening	A clear 850mm wide door opening.	A clear 820mm wide door opening located opposite the shower.
Door design	Either: 1. A slide door, or 2. A door that opens outwards, or 3. A door that opens inwards that is clear of the circulation area and has readily removable hinges.	Either: 1. A slide door, or 2. A door that opens outwards, or 3. A door that opens inwards and has readily removable hinges.
Circulation area	A clear circulation area that is: • A minimum area of 1.2 metres by 1.2 metres. • Located in front of the shower and the toilet. • Clear of the toilet, basin and the door swing. The circulation area for the toilet and shower can overlap.	A clear circulation area that is: • A minimum width of 1 metre. • The full length of the bathroom and a minimum length of 2.7 metres. • Clear of the toilet and basin. The circulation area can include a shower area.
Path to circulation area	A clear path with a minimum width of 900mm from the door opening to the circulation area.	Not applicable.
Shower	A hobless (step-free) shower.	A hobless (step-free) shower that has a removable shower screen and is located on the furthest wall from the door opening
Toilet	A toilet located in the corner of the room.	A toilet located closest to the door opening and clear of the circulation area.

Design guidance

Minimum accessible room dimensions

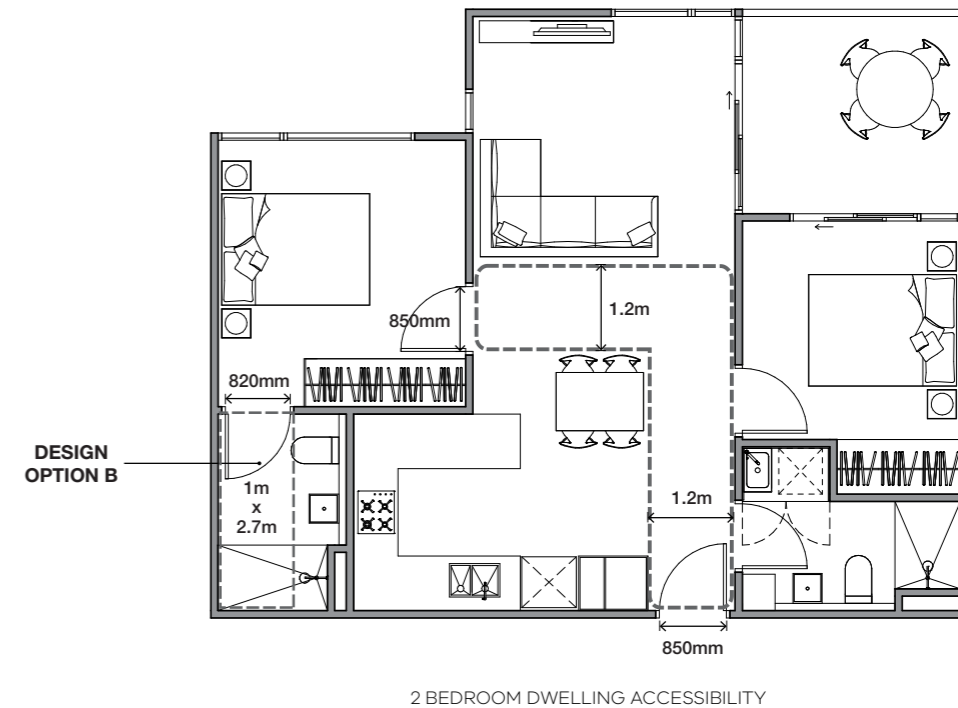
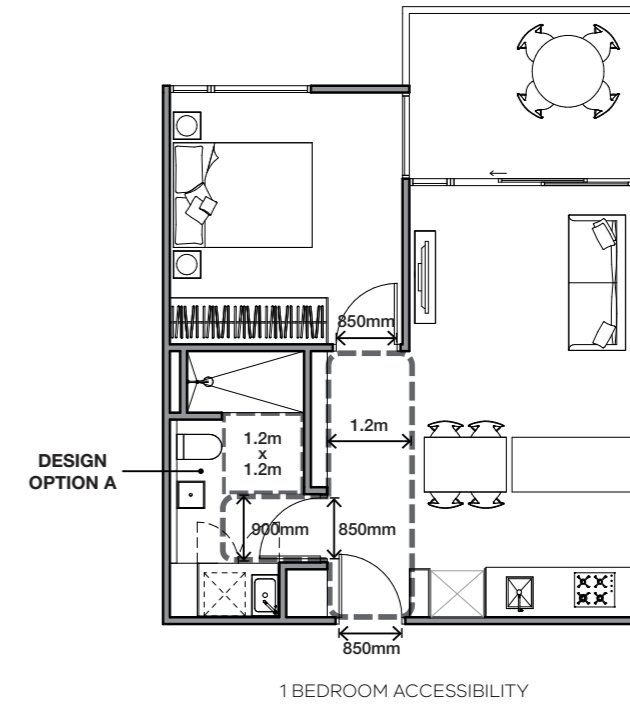

Design guidance

Interpreting the Standard

To meet the design options specified in Table D4 all the requirements of either option A or option B must be met.

For bathroom design option A, a corner of the bathroom is achieved where a nib wall is provided which can be fitted with a grab rail.

1 Locate the main bedroom with convenient access to the adaptable bathroom.

→ GUIDANCE: Where the main bedroom has an ensuite, it should be nominated as the adaptable bathroom.

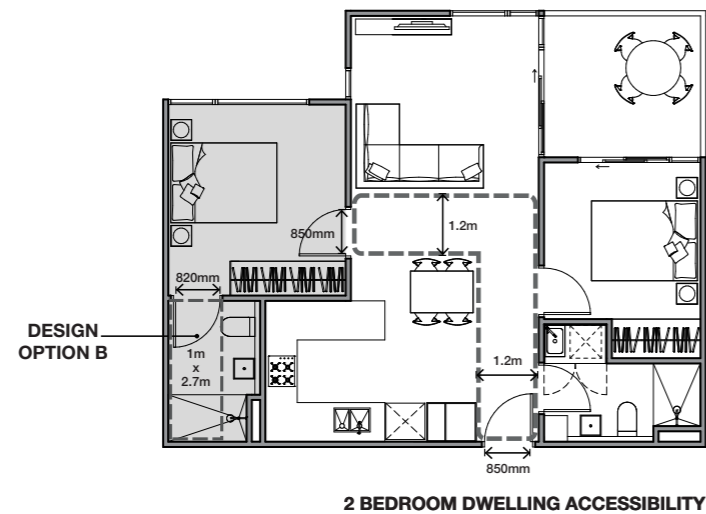

2 BEDROOM DWELLING ACCESSIBILITY

Plan diagram. An adaptable bathroom convenient to the larger bedroom.

2 Configure spaces to achieve clear access paths while allowing for functional furniture arrangements.

→ GUIDANCE: Design openings and the path of travel so that turning movements into bedrooms and bathrooms are minimised.

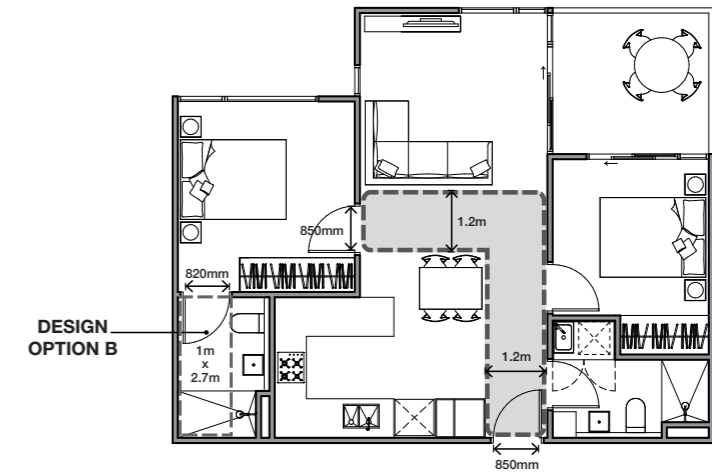

2 BEDROOM DWELLING ACCESSIBILITY

Plan diagram. Clear access paths between entry, living and larger bedroom.

3 When providing an adaptable bathroom to meet either option A or option B make use of the typical configurations illustrated or demonstrate that the standard is met with an alternative layout.

→ GUIDANCE: A step free shower should have a maximum 5mm height level change between adjacent surfaces with a bevelled or rounded edge with falls to the waste outlet.

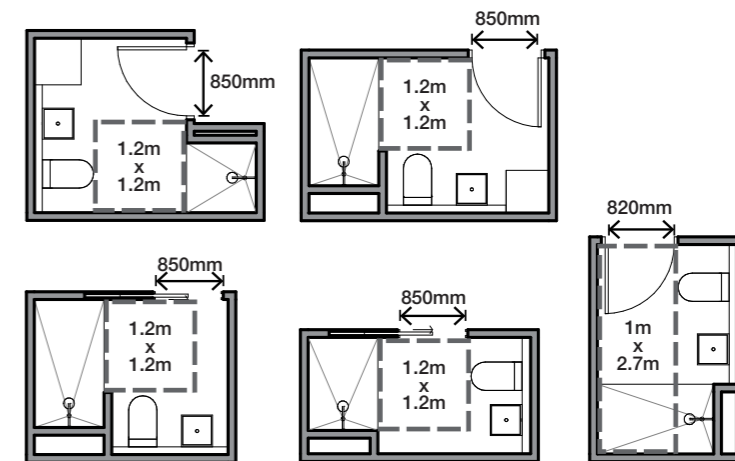

Plan diagram. Typical bathroom configurations to comply with Table D4.

4 **When applying bathroom design option A, if the toilet cannot be located in the corner of the room, include a nib wall adjacent to the toilet**

→ GUIDANCE: A nib wall adjacent to a toilet needs to be 700mm long to enable future fitting of a grab rail.

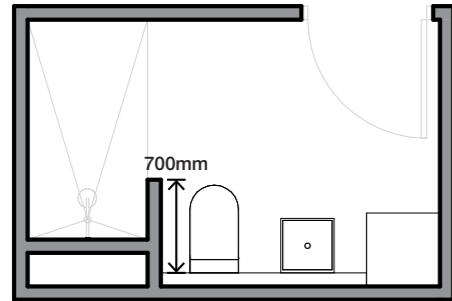

Plan diagram. A nib wall adjacent to a toilet.

Supporting documentation

Identify apartments which have been designed to meet the accessibility requirements.

Provide dimensions for clear openings, pathways and the adaptable bathrooms.

Guidance to construction impacts

Why this is important

The activities necessary to build an apartment development can potentially upset neighbours by increasing traffic; closing roads, bike paths and footpaths; and creating dust, odour and noise. This is potentially detrimental to community health, the safety of pedestrians and cyclists, to movement around the neighbourhood and the environment. The good news is these impacts can be mitigated with a carefully implemented construction management plan.

Construction management plan

Impacts from the construction of an apartment building must be consistently and properly managed.

The responsible authority might manage construction issues in various ways including buyer permit condition. The following model permit condition is a guide.

Model construction management plan permit condition

Before site works — including demolition, excavation and site preparation — start, a construction management plan must be submitted to and approved by the responsible authority. No works are permitted to occur until the responsible authority approved the relevant stage of the plan. Once endorsed, the construction management plan will form part of the permit and must be implemented to the satisfaction of the responsible authority.

The plan must provide details of:

- Hours for construction activity in accordance with any other condition of this permit
- Measures to control noise, dust and water and sediment-laden runoff
- Measures to maintain safe, navigable and step-free public access around and past the site
- Measures to prevent silt or other pollutants from entering into any underground drainage system or gutters within the surrounding road network
- A plan showing the location and design of a vehicle wash-down bay for construction vehicles on the site
- Measures relating to the cleaning and maintaining of surrounding road surfaces
- A site plan showing the location of any site sheds, on-site amenities, building waste storage and the like
- A plan showing the location of parking areas for construction and subcontractors' vehicles on and surrounding the site, to ensure vehicles associated with construction activity cause minimum disruption to surrounding premises. Any basement car park on the land must be made available for use by subcontractors/tradespeople upon completion of such areas, without delay
- A traffic management plan showing truck routes to and from the site
- Swept path analysis demonstrating the ability of trucks to enter/exit the site in a safe manner for the largest anticipated truck associated with the construction
- Measures relating to public safety and site security including the delivery and removal of materials from the site
- Measures to ensure that subcontractors/tradespeople operating on the site are aware of the contents of the construction management plan
- Contact details of key construction site staff
- Any other relevant matters including the requirements of VicRoads and the Department of Transport.

Glossary

Canopy cover

An area of landscaping which is capable of providing shade to people and buildings and contributing to urban heat reduction (such the canopy of a canopy tree or thick vegetation growing over a pergola structure).

Canopy tree

A tree which at its expected mature size is capable of providing summer shade for a person. Table D4 specifies the sizes of canopy trees.

Communal open space

The area(s) of a building at ground level or incorporated in or on the building for the exclusive use of occupants. Communal open space can be indoors or outdoors.

Outdoor communal open space

A type of communal open space that is located externally to a building and provides for outdoor recreation and integrated landscaping.

This page intentionally left blank

Photographers' contact details

Photographer	Email	Phone
Peter Bennetts	pb@peterbennetts.com	0412 568181
Tom Blachford	tom@tomblachford.com	
Tom Ferguson	Tom@tomferguson.com.au	0409 923 335
Christopher Frederick Jones	studio@cfjphoto.com.au	0405 440 180
Rory Gardiner	studio@rory-gardiner.com	0423 800 465
Michael Gazzola	michael@imgco.com	0411 240 200
Gavin Green	gavingreen.com	
Douglas Mark Black	enquiries@douglasmarkblack.com	(08) 430761094
Tatjana Plitt	tatjana@tatjanaplitt.com	0413 684 885
Mr. P Studios	info@mrpstudios.com	(03) 9077 7897
Tom Ross	hi@tomross.xyz	0430 993 866
Ross Honeysett	roho@bigpond.com	0419 409 384
Aaron Puls	info@sjb.com.au	(03) 9699 6688
Greg Elms Photography	greg@gregelms.com	0417 297 368
Scott Burrows Photographer	melbournestudio@scottburrows.com.au	0413 383 940
Trevor Mein	mail@meinphoto.com	(03) 98595699

